

DOCUMENT RESUME

ED 310 939

SE 050 885

AUTHOR David, Leonard
 TITLE Space Station Freedom. A Foothold on the Future.
 INSTITUTION National Aeronautics and Space Administration, Washington, DC. Office of Space Station.
 REPORT NO NP-107/10-88
 PUB DATE 89
 NOTE 49p.; Colored photographs and drawings may not reproduce well.
 PUB TYPE Reports - Descriptive (141)

EDRS PRICE MF01/PC02 Plus Postage.
 DESCRIPTORS *Aerospace Technology; Engineering Technology; Planning; *Satellites (Aerospace); Science Materials; *Science Programs; *Scientific Research; *Space Exploration; *Space Sciences
 IDENTIFIERS *Space Station

ABSTRACT

This booklet describes the planning of the space station program. Sections included are: (1) "Introduction"; (2) "A New Era Begins" (discussing scientific experiments on the space station); (3) "Living in Space"; (4) "Dreams Fulfilled" (summarizing the history of the space station development, including the skylab and shuttle); (5) "Building a Way Station to Worlds Beyond" (illustrating an approach to building the space station); (6) "Orbital Mechanics" (discussing the maneuverability of the space station, including robotic application); (7) "Evolving with Versatility" (describing blueprints for expanding a space station); and (8) "Foothold on the Future" (discussing the future plans of the space station program). (YP)

 * Reproductions supplied by EDRS are the best that can be made *
 * from the original document. *

ED310939

SPACE STATION FREEDOM

A Foothold
on the Future

U.S. DEPARTMENT OF EDUCATION
Office of Educational Research and Improvement
EDUCATIONAL RESOURCES INFORMATION
CENTER (ERIC)

This document has been reproduced as
received from the person or organization
originating it.

Minor changes have been made to improve
reproduction quality.

• Points of view or opinions stated in this docu-
ment do not necessarily represent official
OERI position or policy.

SE 050 885

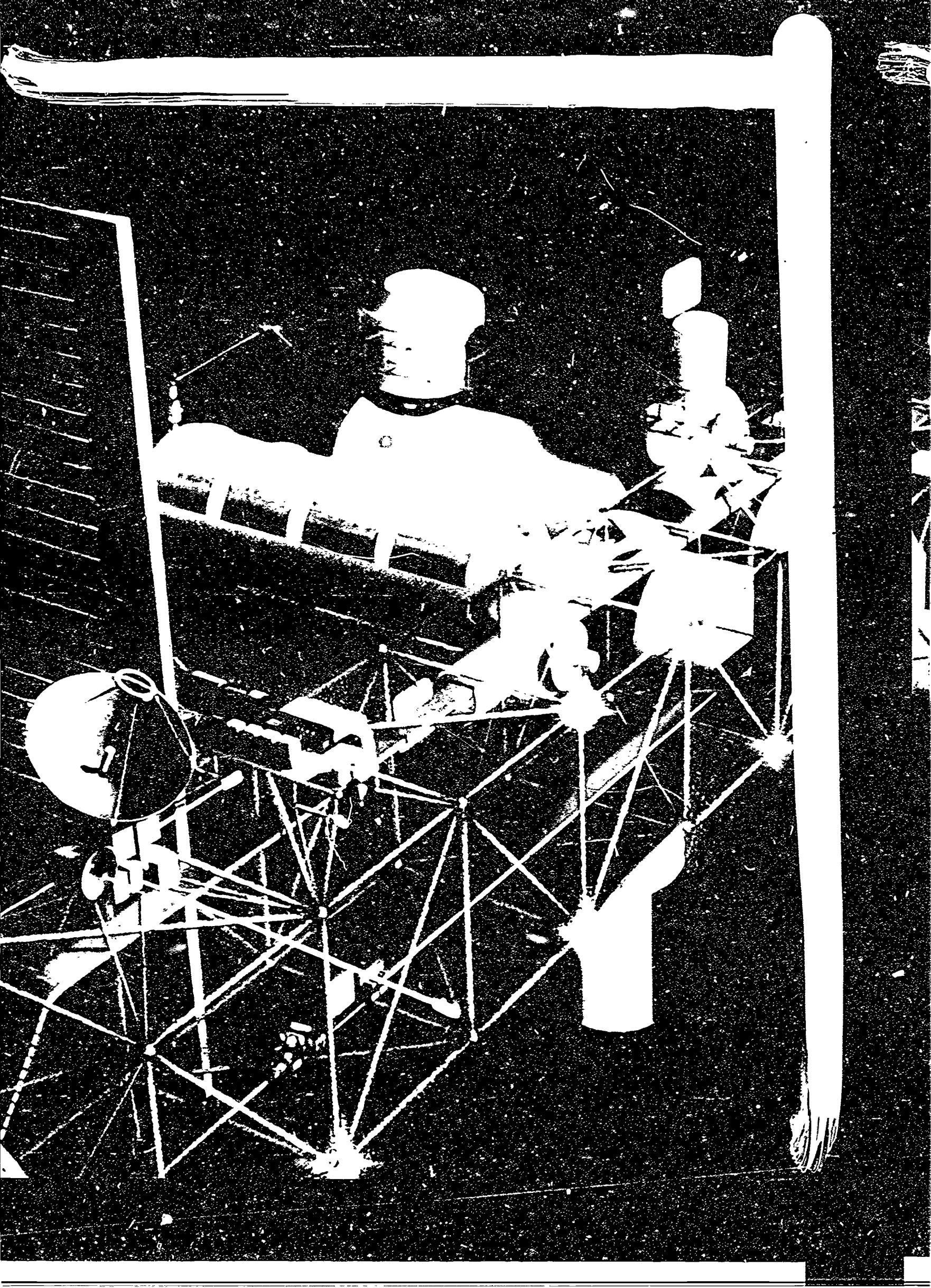



SPACE STATION FREEDOM

A FOOHOLD ON THE FUTURE

by Leonard David

for the

National Aeronautics and
Space Administration

Office of Space Station

Introduction	2
A New Era	6
Living in Space	16
Dreams Fulfilled	20
Building a Way Station to Worlds Beyond	26
Orbits' Mechanics	32
Evolving with Versatility	36
Footholds on the Future	40

Freedom will be an international research center in space, and an orbital base for future missions to extend human presence out of Earth orbit and into the Solar System.

INTRODUCTION

Throughout the long sweep of history, the quest to push back frontiers on Earth has started with discovery and exploration, followed by settlement and economic development. Indeed this is how the length and breadth of our country was developed. In a sense, therefore, Space Station Freedom signals the early stage of our permanent settlement in low-earth orbit. Backed by over three decades of scientific data gleaned by space satellites and human space voyagers, this new international laboratory, anchored in Earth orbit and inhabited and tended by humans, will help us master and develop the space frontier.

The United States is not alone in its attempts to tame space. Many nations see a bright future in exploring and exploiting the space frontier for world prominence, national strength, and commercial profit. Japanese, German, and French industry-government teams are currently formulating space-based programs in micro-gravity research and other space services, including remote sensing of Earth. And since 1971 Soviet cosmonauts have been regularly departing to and from Earth to operate stations in space, achievements that lead many experts to expect bolder Soviet missions in the future, perhaps a mission to Mars.

During the early planning years, experts called a space station the next logical step for America's space program. Today, that space station, christened Freedom by President Reagan in 1988, is becoming part of America's foothold on the future. If America is to demonstrate

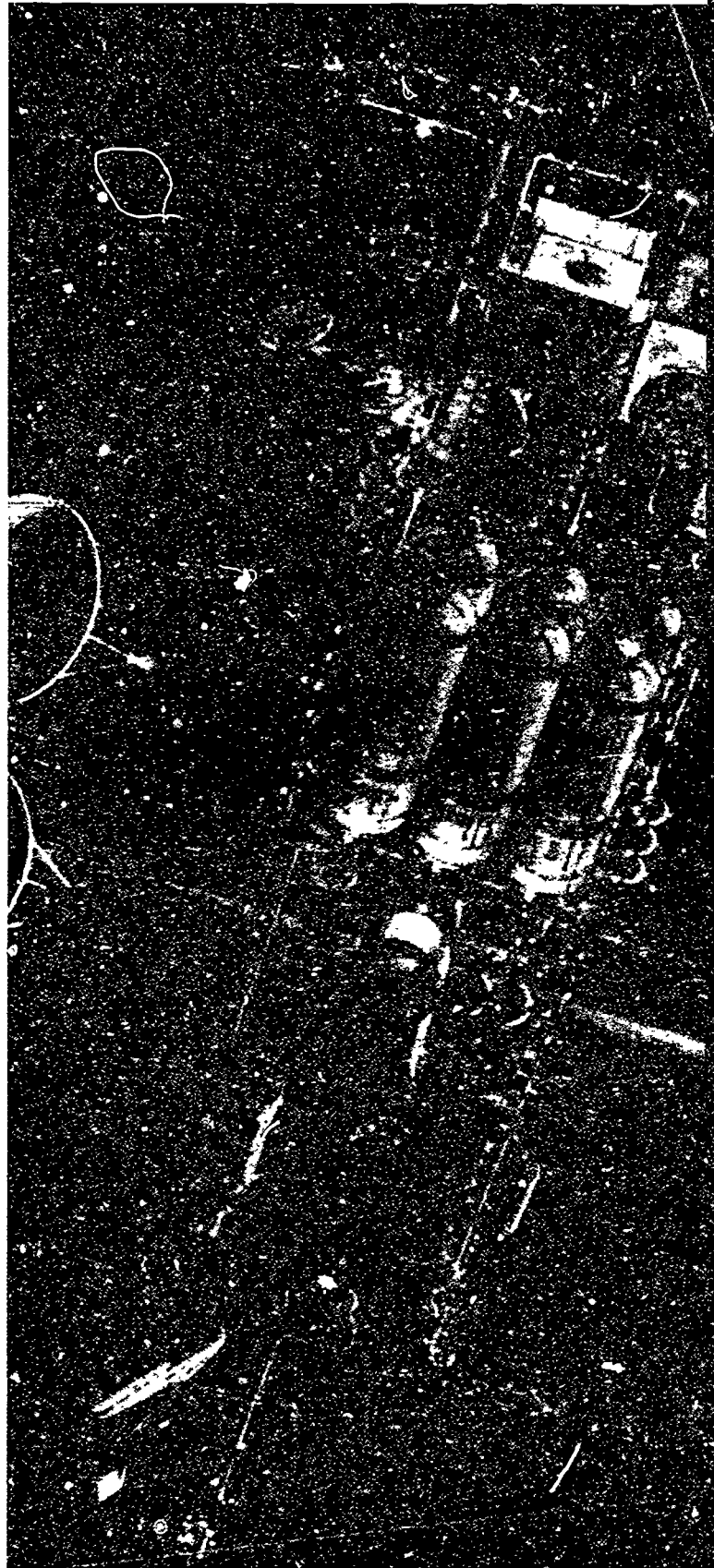

An artist's view of an evolutionary space station serving as a "Spaceport" in low Earth orbit.

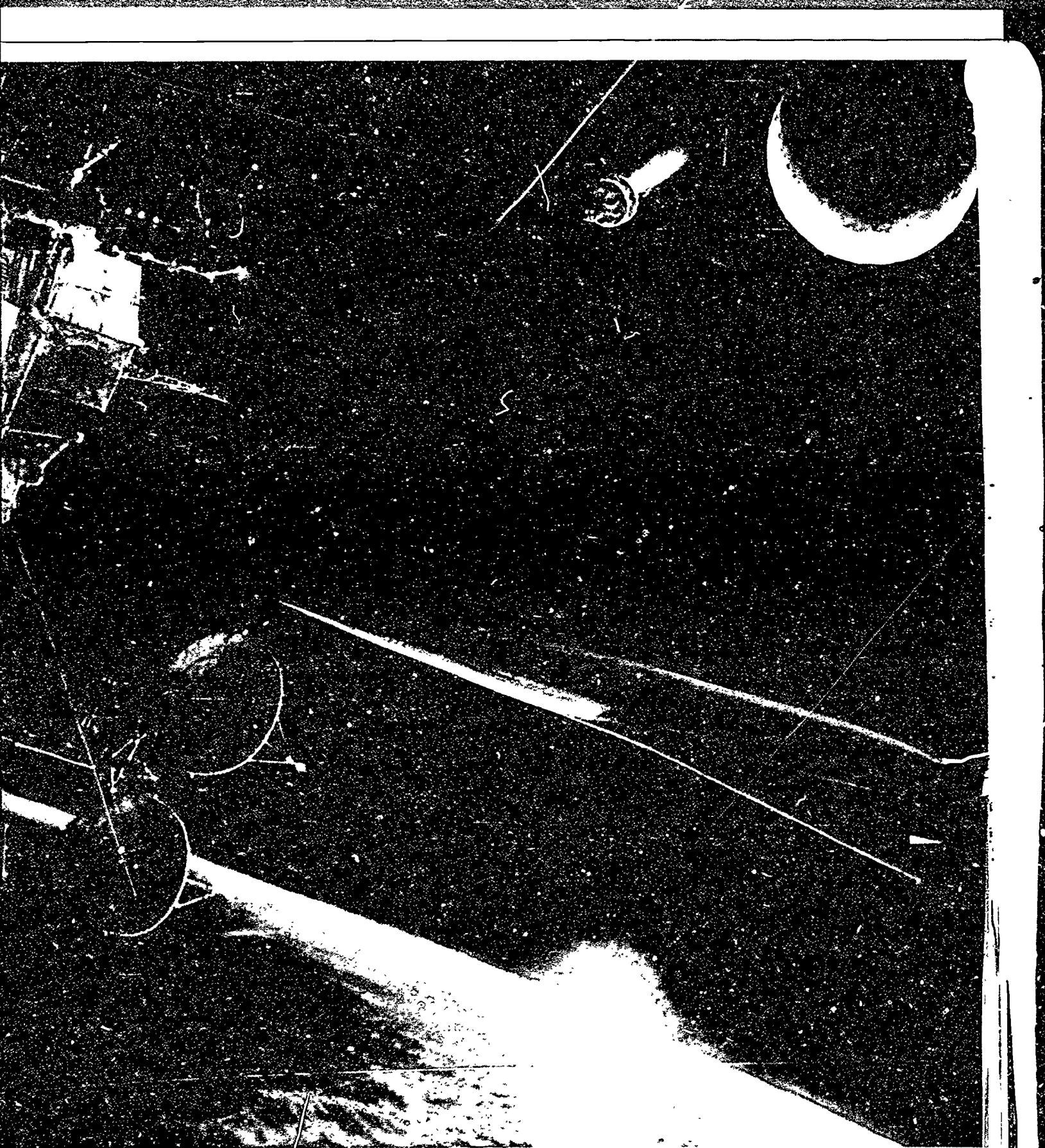



aggressive leadership in space, we cannot rest on our laurels. Space Station Freedom will go far to ensure our competitive edge in space, and contribute to American pride and prestige.

The ultimate purpose of Space Station Freedom is to serve as our rite of passage into the solar system, honing our technical expertise and yielding valuable experience about living and working in a nearly gravity-free medium. By providing an evolutionary base for expeditionary crews, and storage for hardware, propellants, and supplies, Freedom will become a gateway to the Moon and the distant surface of Mars.

Research on Freedom will spawn new scientific and technical breakthroughs that will contribute to our

understanding of fundamental laws of nature, to America's future economic prosperity, and to the quality of life on Earth for all human kind.

The loss of Shuttle Challenger and its crew served notice that pioneering the space frontier is not without risk. America, however, must remain steadfast in its aspirations. By assembling a permanent habitat above Earth, America will find itself conveniently anchored off shore, ready to sail for still longer voyages into space. In this way we will increase our storehouse of knowledge, gain a new perspective of Earth and the universe, open new opportunities for commercial benefit, and nurture our spirit of exploration.

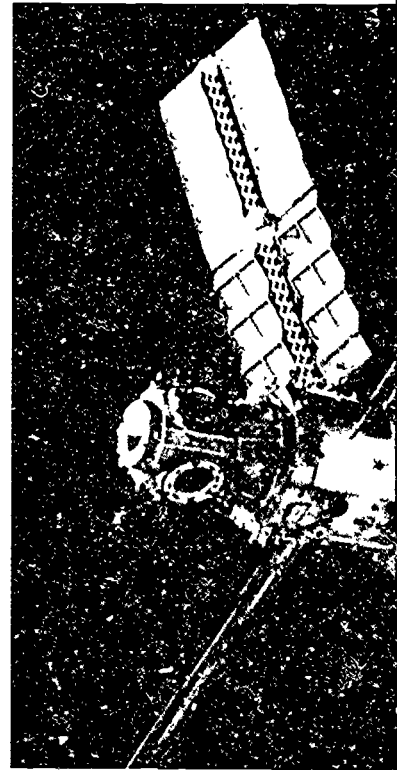

Freedom will provide an evolutionary base for expeditionary crews, a gateway to the Moon.

© 1985, *Rohm and Haas Engineering



America's space program of today is built upon a foundation of over 3 decades of pioneering achievement. From the tentative steps of human space exploration, to the first steps on the Moon, to the Space Shuttle, the Freedom Station symbolizes a commitment to maintain leadership in the exploration and utilization of space.

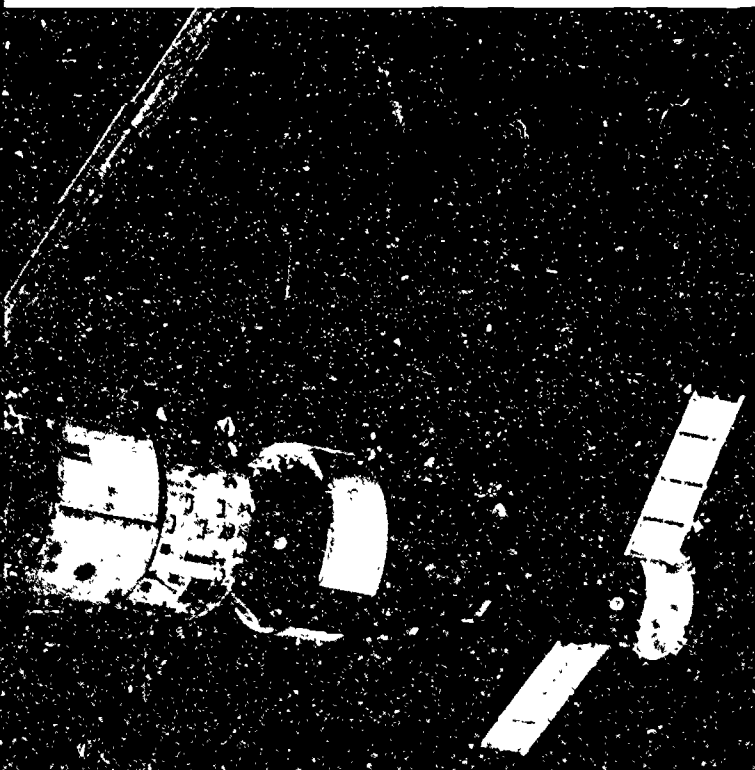

The Soviet Union's "Mir" space station, orbiting Earth since February 1986, is replete with a special docking port to enlarge the station over its many years of productive life in space.



Ozone concentrations in the Southern Hemisphere as photographed by an orbiting satellite. Sensors aboard Freedom's manned base and polar platforms will study our globe from space, probing the relationship between human activity on Earth and the planet's delicate biosphere.



The distant surfaces of Mars.

A NEW ERA BEGINS

In the mid-1990s, a four-member crew will climb out of a Space Shuttle, pass through an air lock, and board Space Station Freedom. Safely housed more than 320 kilometers (200 miles) above Earth in a pressurized environment approximating that on Earth, the astronauts will then watch as their transport vehicle is piloted away from the Freedom station for reentry.

For the next 30 years or more, Space Station Freedom will be permanently occupied. Shipping through the harsh vacuum of space, it will circle the globe in a low-inclination orbit of 28.5 degrees to the equator. Over time, the drag of thin, remnant atmosphere will pull Freedom toward Earth, but periodic bursts from onboard thrusters will prod the facility back into operational altitude.

Inside Freedom's pressurized modules, every available area will be in use, with ceiling, wall, and floor space all designated for experiments, storage, control panels, and electrical power connections. Of course, without the persistent pull of a one-gravity force, there is no up or down in space. Freedom's designers, therefore, will use lighting, computer displays, controls, and even airflow to recreate some of the up-and-down feeling humans are used to on Earth.

Crew members pass from a docked Shuttle orbiter into Freedom's habitation module through a pressurized "resource node." Astronauts monitor docking from a cupola mounted atop the node.

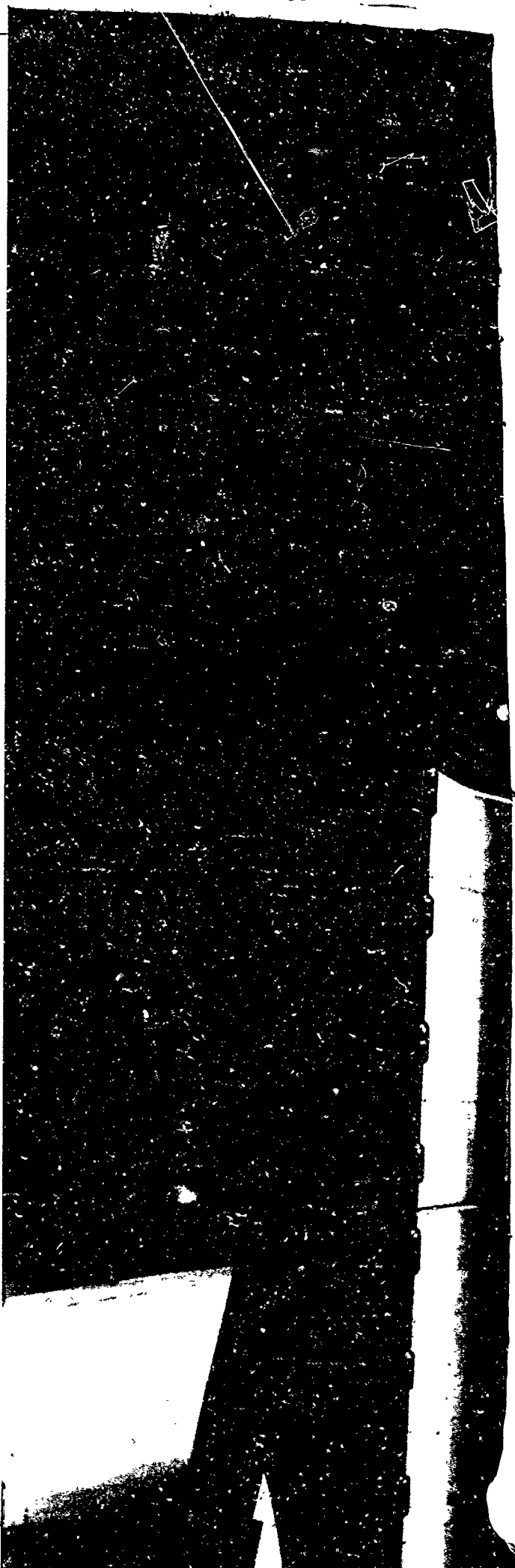

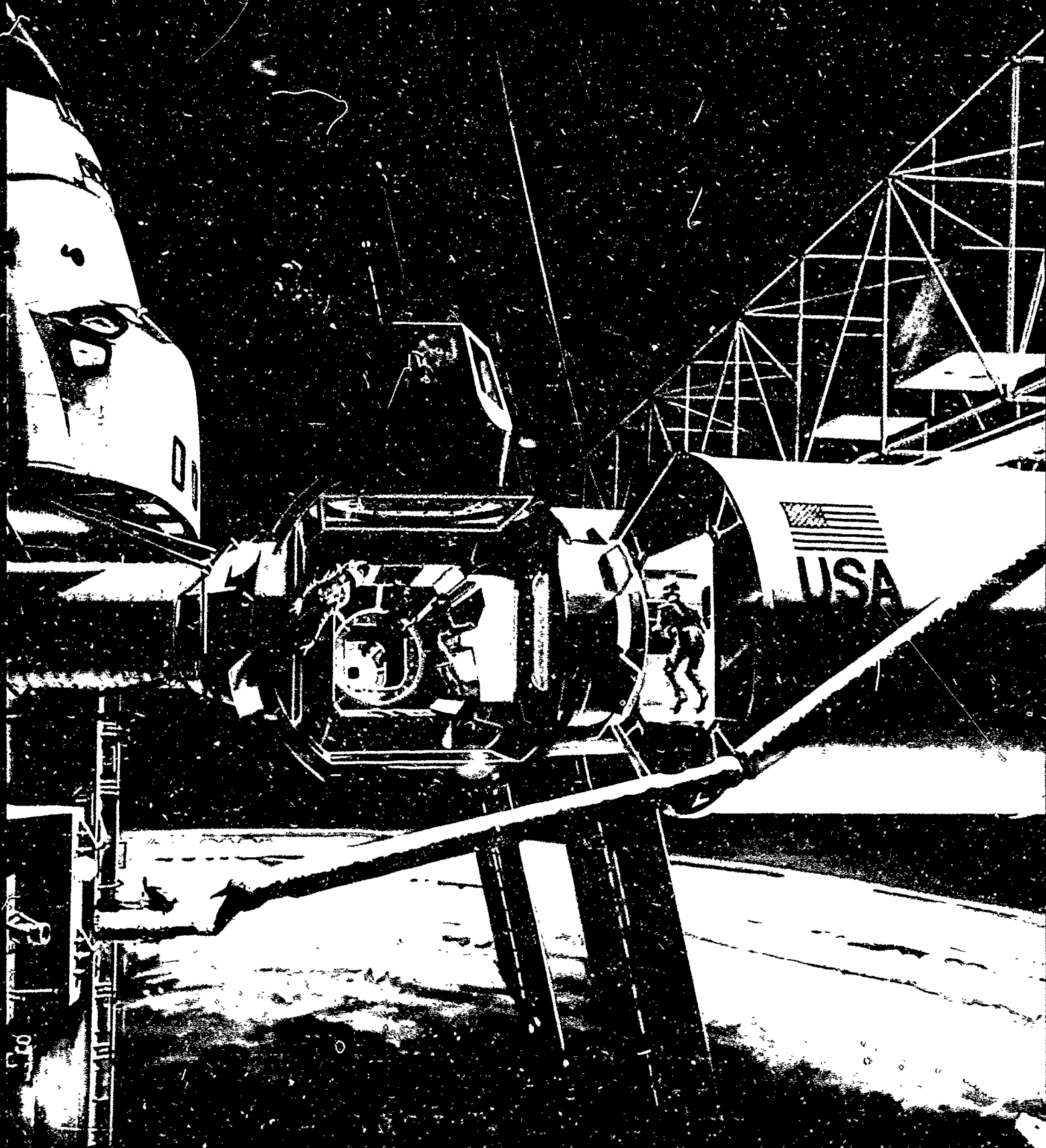

Conducting Science in Space

Once assembly of Freedom is complete, eight crew members — the commander, operators, payload specialists, and mission scientists from the United States and space partner countries — will be on board. Floating free inside Freedom's pressurized modules or tethered outside to its truss, they will work as integrated teams in 9 hour shifts, 5 days a week.

Outfitted with a diverse set of hardware and elaborate instrumentation, Freedom will be an upward, downward, and inward looking international research base. It will be a site for conducting basic research in physics, chemistry, and life sciences, for processing materials, for monitoring Earth's fragile environment, and for developing new technologies. Servicing of attached instruments and reusable spacecraft, and assembly and checkout of large structures will be performed at Space

the permanently manned facility are advances in materials science and life sciences. These are the scientific areas that can most benefit from Freedom's extensive capabilities and from human supervision and interaction.

One important research activity to be conducted aboard Freedom will concentrate on the basic structure of protein molecules, the building blocks of life. Protein crystallography, a technique to be implemented using devices in the U.S. laboratory module, is a relatively new and exciting discipline that will be further stimulated by space borne experiments. Crystallography is a powerful way to determine the three dimensional structures of large molecules. Knowledge of structure provides a key to understanding the basic mechanisms of life. Many of the molecules essential for living mechanisms — especially the proteins and nucleic acids — are very large molecules with extremely complicated three dimensional structures. To deter-

minish these structures, crystallographers coat biological molecules to organize symmetrically into crystals big enough to study. They bombard these molecular crystals with X rays to create diffraction patterns, which computers analyze.

Growing protein crystals good enough to study is extremely difficult. Despite tremendous efforts, researchers have crystallized relatively few proteins successfully, and imperfections often mar the rare large crystals grown under normal circumstances. However, space experiments suggest that larger and more perfect crystals form in the absence of gravity.

Previous experiments have demonstrated the feasibility of growing large protein crystals in microgravity without the formation of multiple seeds, which produce numerous small crystallites that would

Station Freedom. Ultimately, Freedom will be a point of departure to interplanetary space.

Complex experiments will be performed within Freedom's pressurized, shirt-sleeve laboratories, providing many important clues to the basic laws of physics that govern the delicate interaction between gravity, humans, and materials. The primary research objectives of

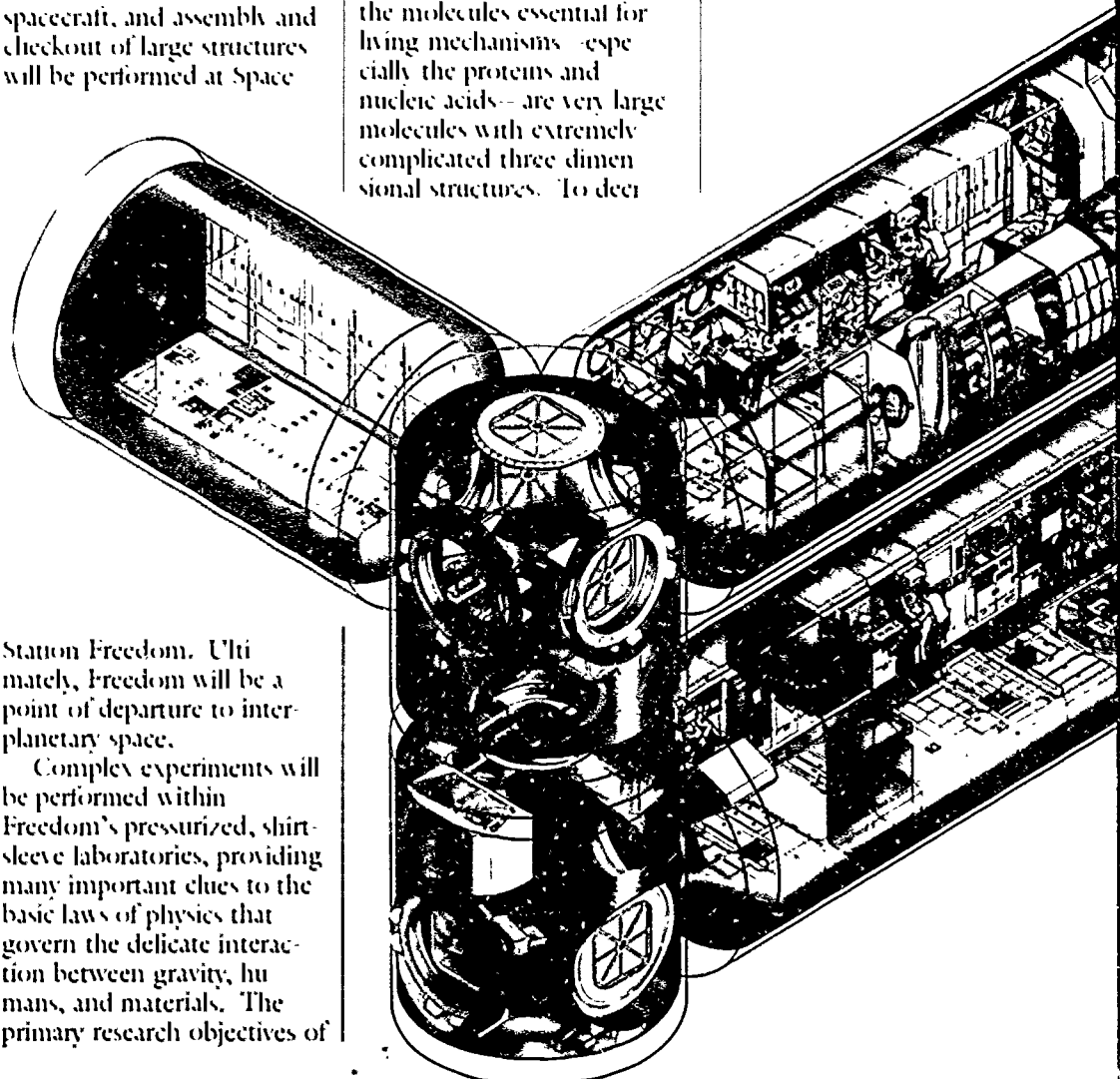

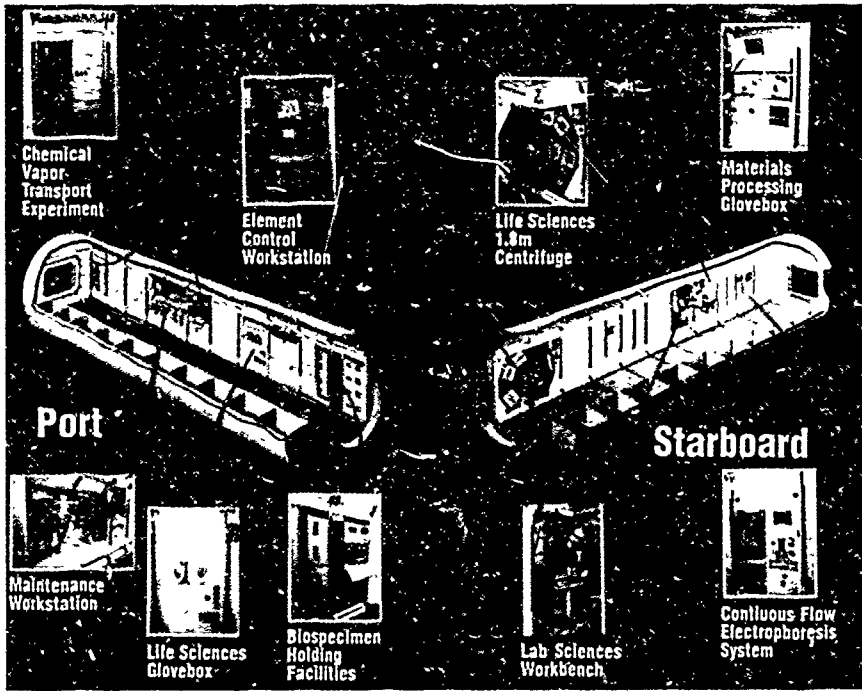

The U.S.-built laboratory module will house hardware designed to conduct materials and life sciences investigations. Equipment will be similar to devices found in well-equipped ground-based laboratories.

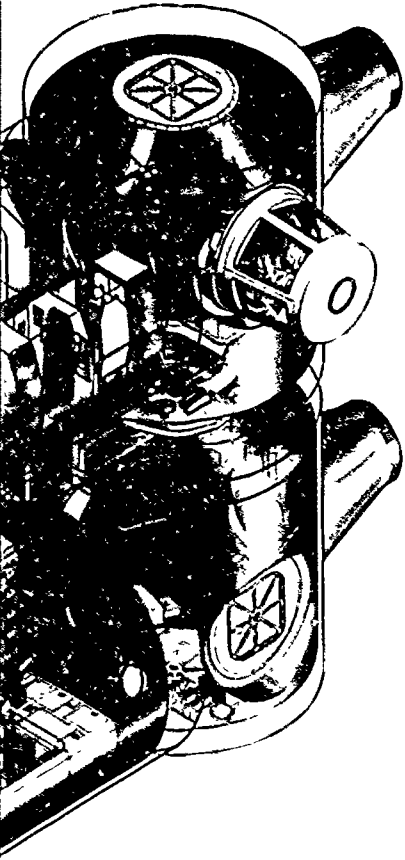

Configuration of U.S. modules shows the habitat module (top center); laboratory module (below habitat module); logistics module (far left) for storage and transport of supplies and experiments; and resource nodes which interconnect the modules and house command and control systems.

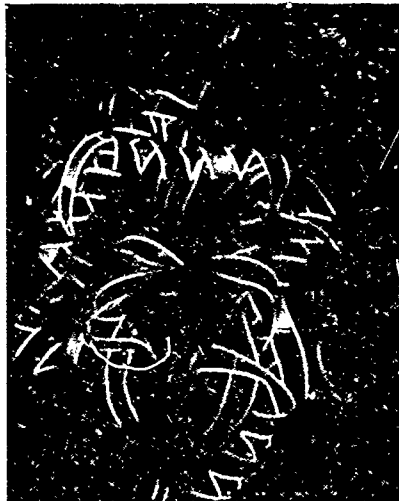

Protein crystals, like these...



may prove to be of major benefit to medical technology.

preclude study by X-ray diffraction techniques. Protein crystals grown aboard Freedom will be large enough, and of sufficient quality, to be studied by conventional crystallography. Once their three-dimensional molecular structure has been determined, these new products may be synthesized on Earth through bioengineering techniques, and steps can be taken to alter, enhance, or eliminate the protein effects in the human body. There are potential applications to the treatment of human diseases and disorders, and to organ transplants and implants.

Other fundamental areas of investigation to be explored within Freedom's laboratory module include properties of pure metals, segregation effects in alloy solidification, the microstructure of castings, nucleation and growth phenomena in the absence of container-wall effects, and the process of rapid solidification of highly undercooled melts. For example, the formation of dendrites—whisker-like growths similar to structures found in snowflakes—may be studied in detail. Dendritic growth is an important feature of solidification, with implications for the strength of castings. The high vacuum of space also may be utilized in metallurgical studies. In combination with containerless processing, a vacuum system offers unique opportunities to study metal purification and the basic properties of ultrapure or high corrosive materials.

The understanding of room-temperature and cryogenic fluid behavior is a key to microgravity research generally, since nearly all materials are processed in their fluid state. Specific experiments performed aboard Freedom could examine processes and phenomena related to droplet and bubble dynamics, phase transitions, capil-

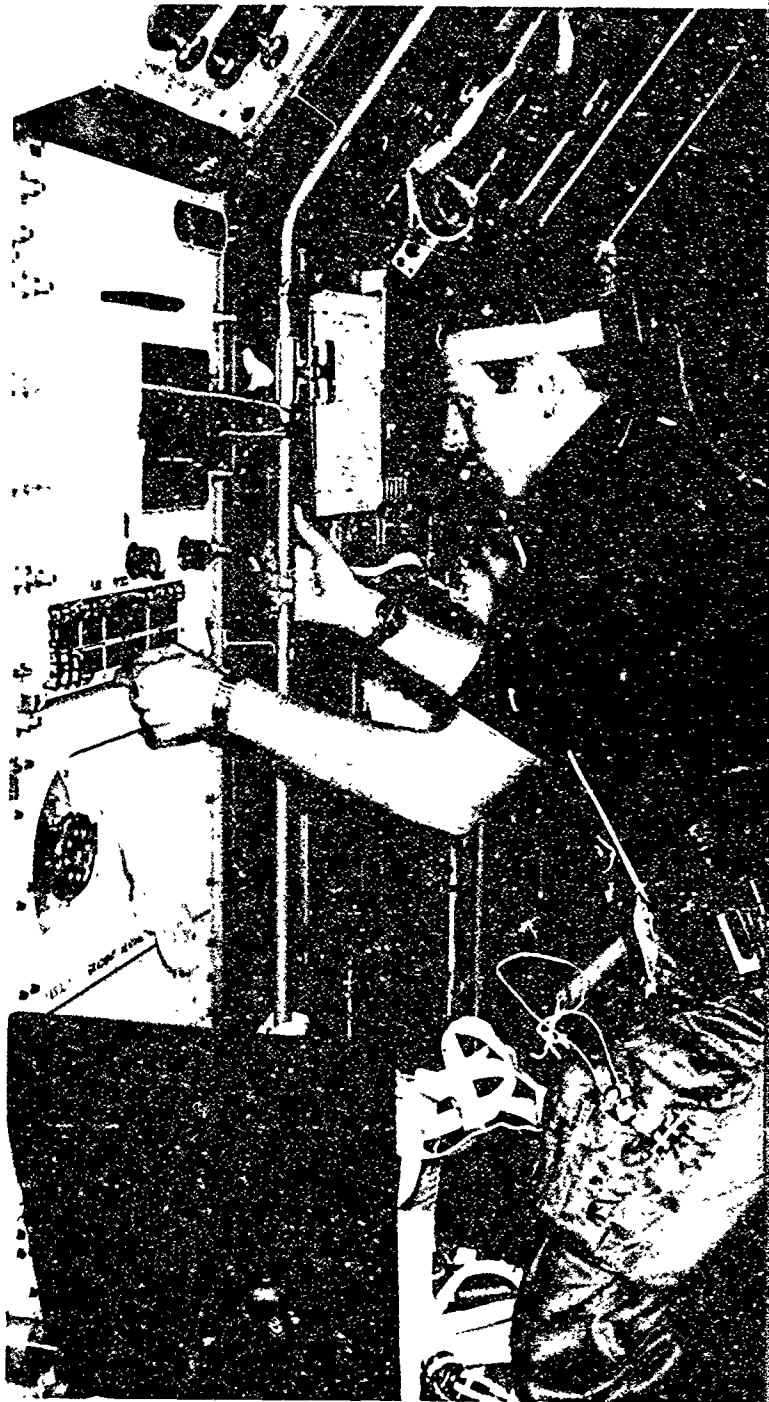

Ability to perform materials sciences investigations, similar to those performed here by Byron Lichtenberg on the Spacelab 1 mission, will be dramatically enhanced by Space Station Freedom.

Right: Spacelab 3 payload specialist Taylor Wang manipulates sphere in a device which served as a forerunner to a containerless processing facility being developed for Freedom.



Below: Life sciences investigations, like this heart-monitoring echocardiograph being connected by Dr. Rhea Seddon to Jeffrey Hoffman during a Shuttle mission, will study the effect of microgravity on plant, animal and human organisms.

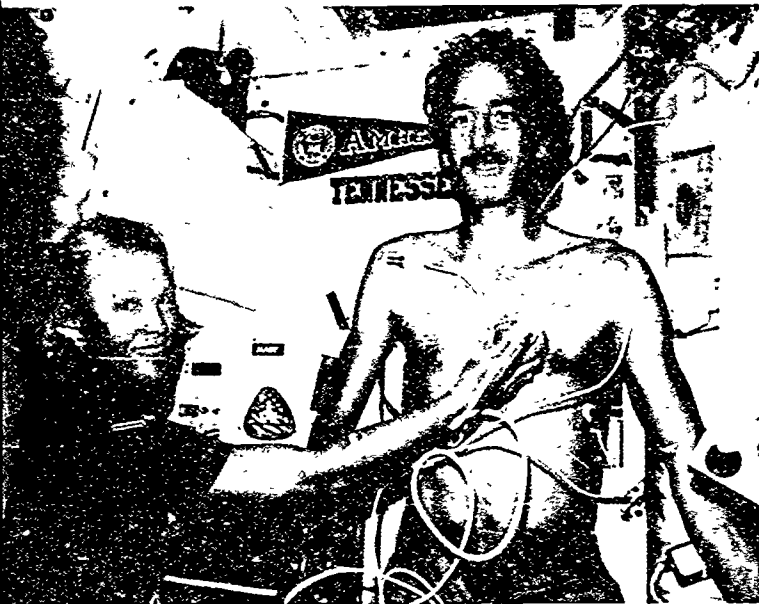

lary processes, forced multi-phase flows, nucleation and cluster phenomena, and electrohydrodynamic effects. Additional fundamental research will provide improvements in measurements of thermophysical properties and furnish data relevant to a wide variety of applications, including liquid propellant storage and transfer, micro-encapsulation of biomedical materials, meteorology, and the study of planetary interiors.

Space Station Freedom will give researchers a powerful facility for conducting research in the microgravity sciences. Microgravity research presents opportunities for fundamental research advances, some of which could have landmark impacts on science and technology. Six microgravity Freedom Station's laboratory module are:

Biotechnology Facility to study the microgravity effects on biological pro-

cesses and living organisms at the cellular level. This facility would permit a detailed study of the response of various cells to microgravity under carefully controlled conditions.

Advanced Protein Crystal Growth Facility to grow high-quality crystals, to obtain the highest degree of long range order in the crystalline lattice, which determines the precision with which X-ray crystallographers can determine the structures of these complex biologically active molecules.

Modular Containerless Processing Facility to provide basic support for a wide range of experiments that require the positioning and manipulation of samples without physical contact. Acoustic, electromagnetic and electrostatic fields will provide the forces to manipulate the sample. Experiments to be performed in this facility will range from tests of theories that describe

the behavior of liquid drops to the processing of molten materials at high temperatures.

Space Station Furnace Facility for study of metal and alloy solidification and crystal growth with applications to electronic devices and development of materials with unique or improved properties.

Modular Combustion Facility to study fundamental combustion processes and phenomena and provide data for combustion-related applications such as fire safety and control and advanced furnaces.

Fluid Physics/Dynamics Facility to provide a better understanding of fundamental fluid behavior which is essential to developing processes that take full advantage of the microgravity environment.

Equally important are detailed studies in life sciences. Life on Earth, from microbe to man, has been shaped by gravitational forces in ways that are only now beginning to be revealed by space investigations. Previous space missions have confirmed a complex interaction between gravity and life, but these have been too limited or constrained to permit authoritative biological research. Space Station Freedom—offering controlled examination of a variety of species in long-duration microgravity under the skilled supervision of a resident crew—will present research opportunities unparalleled in the history of life sciences.

Freedom's laboratory module will permit extraordinary advances in biology. Variable-gravity research conducted aboard Freedom will seek to advance our knowledge of fundamental biological processes. A major objective of this



Given FreeJom's vantage point, experiments can be carried out to observe Earth's solid surface, atmosphere, oceans and ice deposits.

research is a deeper understanding of the relationship between gravity and life, as revealed through synergistic experimentation across a suite of species ranging from single-cell organisms to human beings.

In the area of space physiology, researchers will exploit the ambient microgravity environment, together with the variable gravity produced by specially designed research centrifuges, to examine the physiological effects of gravity on mammalian systems, especially human systems. Experiments will focus on the mechanisms by which gravity influences bone and muscle, fluid and hydrostatic systems, orientation in space, homeostatic control, and response to environment. Data gleaned from these experiments will help lift the veil of mystery surrounding human adaptation to space flight, a necessary feat before extending the human presence

further into the solar system, and are expected to have wide-ranging clinical applications on Earth, such as in the treatment of bone-degrading diseases such as osteoporosis.

Gravity plays a key role in the development of most, if not all, biological systems. The opportunity to examine microorganisms, plants, and animal species throughout multiple life cycles in a microgravity environment is unprecedented in the history of biology. Experiments will focus on identifying the organ or site of gravity reception; determining the effect of gravity on reproduction, development and maturation, and investigating physiological responses. In particular, this program will sponsor scientific studies of life born and raised beyond Earth. Research in this field may have practical applications for computer scientists. The discovery that gravity-sensing cells in mammals also act as parallel processors gives scientists a simple

device to study. Experimenters now hope to produce a dynamic model of a mammal's neural network, which could be used as a model to design machines capable of artificial intelligence.

Experimental modeling of gas-gram interactions can also be carried out in

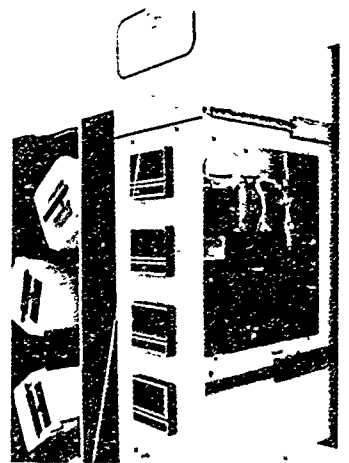

Mockup of 1.8 meter centrifuge for life sciences investigations.

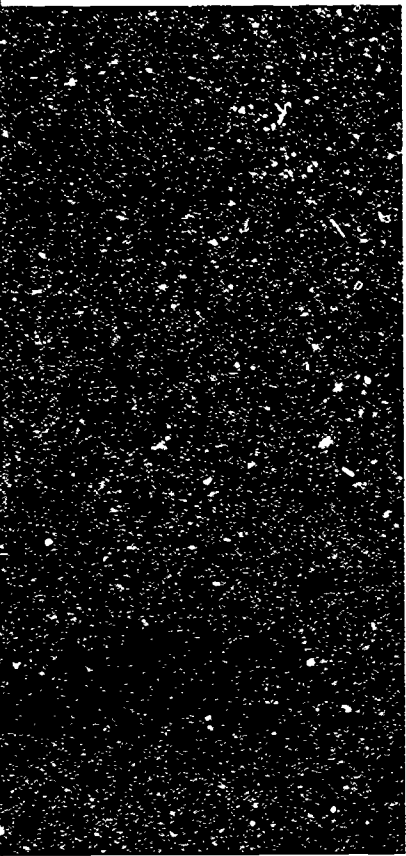

Freedom's laboratories, with applications to the origin of life, particularly the cosmic history of organic molecules from the formation of biogenic elements to their incorporation into living organisms.

Research on Freedom will promote the development of a bioregenerative life-support



Making use of the Freedom—its crew and high sensitive instruments—Earth's star, the Sun, can be continuously observed. Dynamic Sun-Earth relationships, studied from the Station, may yield valuable clues about the effects of solar phenomena on the Earth.

technology for use within the spacecraft. This research will investigate the use of plants and microorganisms to perform in space the same functions performed on Earth—production of oxygen, potable water, and food from biological wastes. One of the practical benefits of designing agricultural systems for use in space is that it could contribute to developing new intensive farming practices in extreme environments on Earth. The design of small, efficient plant growth chambers may also have practical value in urban areas, in regions where growing conditions are not right for a particular crop, or in extreme environments such as the Antarctic or deserts. And, aside from its importance in food production, closed ecological life support system research may provide a model of other closed environments, such as modern insulated houses, where plants act as natural "scrubbers" to remove air pollutants.

Freedom's expansive horizontal truss will provide attachment points for payloads designed to study the Earth and its environment, the sun, other bodies in the solar system and cosmic objects. Attachment to Freedom Station offers a number of advantages, including provision of electrical power, communications and some pointing capabilities furnished by Freedom itself, together with opportunities for resupply of consumables and instrument exchange by Freedom's resident crew.

NASA has already identified many promising candidate payloads that can benefit from Freedom's orbit, configuration and operation. One exciting experiment under study is Astromag, which would use a powerful superconducting magnet for unravelling aspects of mysterious cosmic rays and begin an unprece-

dent study of the origin and evolution of matter in the galaxy by direct sampling of galactic material. The experiment will produce a magnetic field one thousand times the strength of Earth's magnetic field. To achieve its superconductivity, the device will be cooled by liquid helium brought up by the Shuttle and resupplied periodically by Freedom's crew.

Freedom will also support exobiology and solar system research. Freedom provides an unprecedented opportunity to collect intact fragments of interplanetary dust particles, the "fossils" of early solar system development, and possibly interstellar particles for post-flight analysis. For example, a Cosmic Dust Collector, attached to Freedom's truss, will snag the finely divided solid matter—a substance that may offer clues to the origin of the universe. A high-resolution, Astrometric Telescope Facility, designed to peer deep into the surrounding universe with superior pointing accuracy, may also be mounted to Freedom's frame. This device will look for planets around other stars.

We are just beginning to appreciate the complex and highly volatile Sun-Earth relationships. Equipment fitted outside Freedom's pressurized modules, such as the Solar Terrestrial Observatory, promises to advance our understanding of solar features and properties and of the ebb and flow of electrical plasma, the solar wind cast off from the Sun before interacting with Earth. Other prospective attached payloads include a Large Area Modular Array of Reflectors for surveys of cosmic X-ray sources at low resolution and high sensitivity, and a Pinhole Occulter Facility for mapping of solar X-rays.

Although the manned base is only a few hundred

miles above sea level, it is similar in many ways to a remote laboratory in the Arctic. In both cases, transportation across an expanse of space limits laboratory access to a select number of researchers trained to perform on site studies far from most of their counterparts.

Nevertheless, through a process called "telescience," scientists on the ground will be able to interact with their experiments and the crew on-board Freedom and with colleagues dispersed on Earth by networking through voice communication, computer data links, and other communications technologies. In this way, many ongoing research activities on Earth can be integrated with research aboard the Freedom Station. No doubt there will be moments both in space and on Earth when nothing more than a touch of serendipity sparks curiosity, exploration, and discovery.

Earth Observing System in Space

There is now strong evidence for global changes in the Earth's atmosphere, oceans, and land surfaces, caused in part by human industrial and agricultural activity. The extent and long-term character of these global trends have generated worldwide concern and led to the initiation of international research programs to investigate their causes and consequences.

Space technology will play a key role in future Earth observing systems designed to study global change. The United States will provide leadership in this area by providing, as part of the Freedom program, the first polar-orbiting platform to become part of the Earth Observing System (Eos). The U.S. platform is scheduled to be the first of two U.S. platforms for Eos. Additional platforms planned by ESA and Japan will

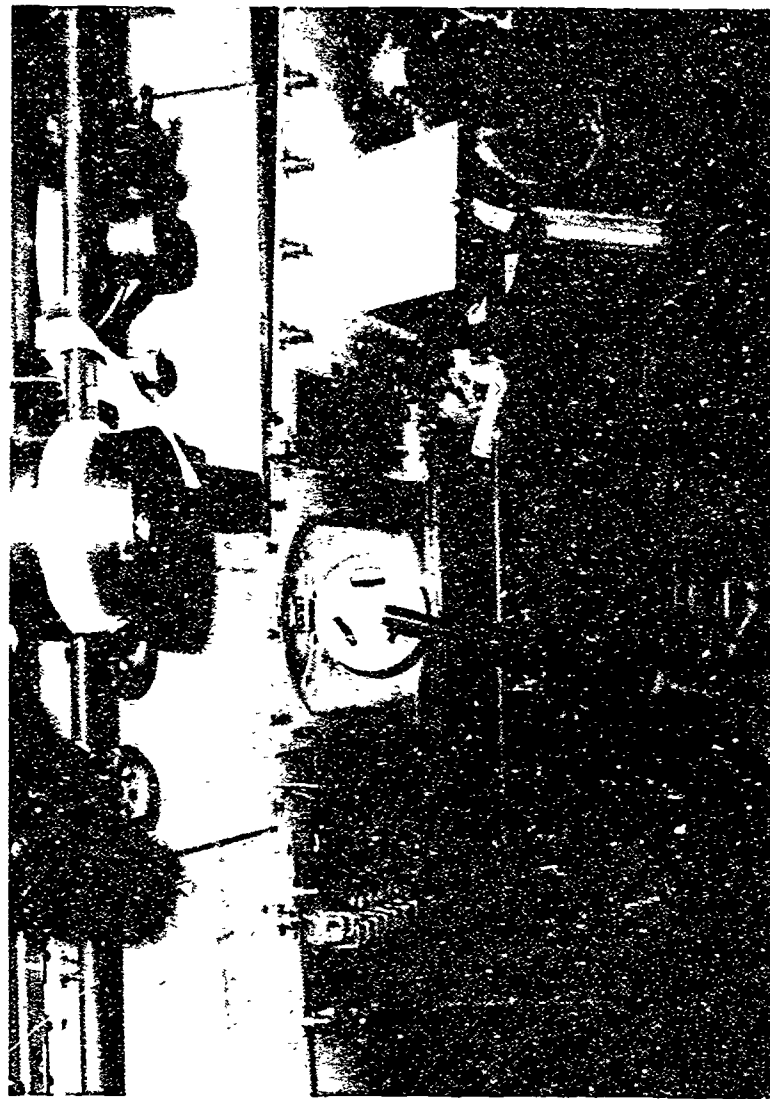

Above: ESA payload specialist Dr. Ulf Merbold, shown here, was a crew member on Spacelab 1. Scientists from the U.S. and other nations see the Freedom as a nexus to innovation and creativity.

complement the Eos missions of the United States platforms and may carry out other investigations.

Instruments on Freedom's U.S.-built platform will be designed primarily to study the Earth's surface and atmosphere. Other instruments, proposed for placement on the manned base, would measure tropical rainfall extent and intensity in the tropics, gather accurate wind measurements using advanced laser techniques, and perform low-latitude surveys of the Earth's surface under a wide variety of illumination conditions.



NASA will encourage private sector participation in space research aboard the Freedom. Charlie Walker, a McDonnell Douglas engineer, flew on several Shuttle flights in support of his company's Continuous Flow Electrophoresis System.

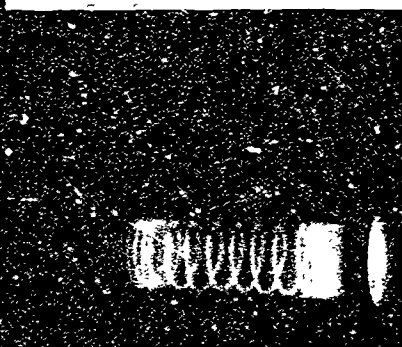
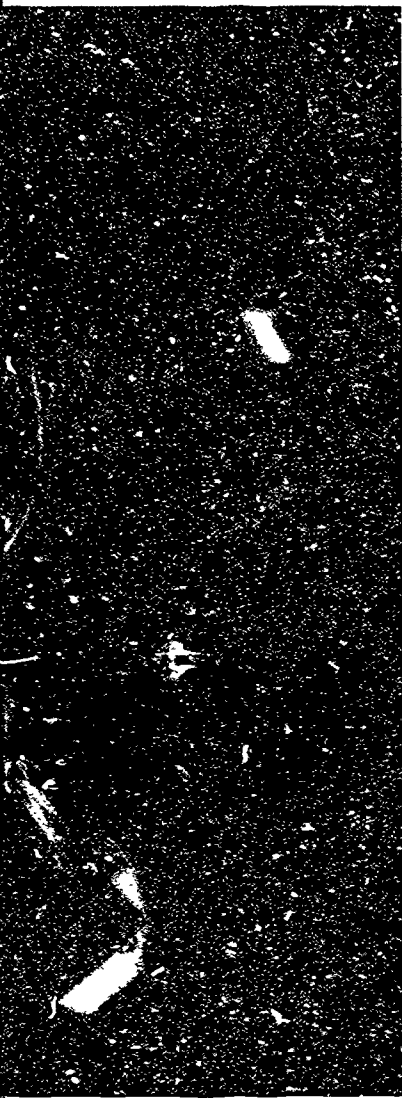

Crystal-growth experiments, like this one developed by Boeing Aerospace for launch aboard the Space Shuttle, will be flown on the Freedom.

© 1988 Boeing Aerospace

A New Commercial Environment

Experiments aboard Apollo, Skylab, the Space Shuttle, and Spacelab offered tantalizing glimpses of ways to use space to create entirely new classes of products and stimulate major advances in ground-based production techniques. In consequence, a cadre of private companies is planning to use Freedom's manned base and platforms, all seeking a return from space-engendered research and development. In addition, cooperative government-industry-academic efforts are contemplated for Freedom, increasing the bank of science and technical data that keeps American industry competitive and aggressive and nourishes the free enterprise system.

In the low gravity of space, for example, materials can be manipulated through processes impossible on Earth. One U.S. company is drawing on results of academic and industrial research carried aboard previous space flights to develop hardware for cultivating crystals in space. By minimizing the effects of gravity, and thereby decreasing the number and distribution of defects, crystals can be grown that are larger and more uniform than their Earth-grown counterparts. These larger, purer crystals could mean faster and more powerful computers, data processors, and special sensors.

Small quantities of some experimental space-produced pharmaceuticals will be made in space with the resulting knowledge applied to ground-based production methods. Ultrapure, bubble-free glass for use in optical instruments, collagen fibers to replace injured human connective tissues, and heat-resistant ceramics for a wide range of high-temperature applications — all are candidate materials that may be enhanced by harnessing

microgravity as a new tool for basic and applied research in space.

And in a role similar to that of a research laboratory on Earth, Freedom's manned base and its associated free-flying platforms can be utilized to add information to an existing data base. Other privately funded work in Earth remote sensing, communications research and development, and industrial services is anticipated.

The hard-nosed business community is looking at the commercialization of space with guarded optimism. This is to be expected since, for the most part, business is attuned to expecting short-term profit from short-term investment. No one knows how this business philosophy will be extended into space.

In this regard it is instructive to look at what other nations are doing. In Japan, Germany, and France, for example, industry-government teams are formulating broadly based programs in microgravity research and other space services, such as remote sensing of the Earth. Teams of Soviet cosmonauts in their Mir space station already have processed the first industrial specimens of semiconductor materials in orbit. A stated Soviet goal for 1990 is to acquire large quantities of made-in-space semiconductor material for application in super-high-speed and super-large integrated circuits for infrared and laser technology; dedicated modules for carrying out this work are to be docked to the Mir.

Thus, as other nations cast an eye toward commercializing the vast potential of space, U.S. companies must take care not to be left behind at the launch pad. Although the risks for quick return on investments in space are high, the long-term payoff for opening the economic frontier of space may be substantial.

LIVING IN SPACE

The cozy common areas inside Freedom's habitation module feature a wide selection of out-of-this-world amenities. One end has areas for quiet-time and personal activities. At the opposite end is an area for socializing. Through a nearby window the crew can observe the earthscape fleeing by, with a sunset or sunrise occurring every 45 minutes.

Between the two living areas are the waste management and personal hygiene facilities. Simple tasks like washing hands are greatly compounded in the micro gravity world of space. Crew members therefore will wash their hands in cylindrical plastic bubbles outfitted with holes rimmed with cuffs. A shower stall provides a combination of flowing air and warm water to take off a day's accumulated grit and grime. A combination washer-dryer for clothing is currently under design.

An environmental-control and life-support system will provide the crew with a breathable atmosphere, supply water for drinking, bathing, and food preparation, remove contaminants from the air, and process biological wastes. The system will be partially closed, thus permitting water and carbon dioxide to be recovered and processed to provide oxygen, potable water, and hygiene water for the crew's reuse.

Dining under the stars takes on new meaning aboard Freedom. A table and the proper restraining devices accommodate all the crew. With a refrigerator-freezer, a microwave, and



Habitation module will include exercise equipment to maintain cardiovascular fitness, and work control stations.



conventional oven on board, meals will be a far cry from the food squeezed out of toothpaste-like tubes during space flights in the 1960s. NASA dieticians, therefore, are putting together a vastly expanded menu drawing on frozen entrees, refrigerated items, stable shelf foods, and a variety of beverages. For a change of pace, ethnic foods will be served; a surprise birthday cake can even be whipped up in the galley. After the meal is finished, a compactor will crush trash, including disposable cooking and eating utensils, into manageable sizes for storage and later transfer to Earth.

Staying Healthy in Space

"Is there a doctor in the house?" When you're far removed from Earth, the query takes on new meaning. No longer required to pump blood against the pull of gravity, muscles atrophy and the heart gets lazy in space. Weightlessness can also cause temporary motion sickness with accompanying disorientation. In flights lasting longer than a month, a significant percentage of red blood cells are destroyed, a form of space anemia not yet understood. Sickness and disease are easily spread in close quarters; potential bouts with injury, psychological trauma, exhaustion, and depression must also be anticipated.

To maintain physical fitness each crew member will go through two 45-minute, individualized exercise programs a day using the treadmills and stationary bicycles in the habitation module. In addition, a Health Maintenance Facility (HMF) in the module will serve as an on-board sick bay. There, illness or minor injuries can be treated, or a more seriously injured crew member can be stabilized.

A compact package of diagnostic and therapeutic medical hardware neatly

tucked into 1.5 cubic meters (5.3 cubic feet) of space and weighing a modest 545 kilograms (1,200 pounds), the HMF holds a microscope, clinical chemistries analyzer, radiographic imager, and hematology laboratory device. Also in this electronic doctor's bag are a patient restraint system and tools for performing minor surgery and dental procedures and administering anesthesia. A data display screen is available for reading the various instruments. A computerized data base, tied to the HMF and downlinked to a consultant network of physicians, ensures speedy access by ground-based doctors to integrated medical information.

Because there won't be room aboard Freedom for an extensive library of medical reference books, researchers at the Johnson Space Center are developing a medical operations data base for use aboard the manned base. Researchers at the University of Florida, under contract to NASA, also are developing a microcomputer-based medical decision support system that can present a small library of essential medical knowledge to medical personnel on Freedom Station. Aside from its use in space, such a computerized medical library could ultimately be put on laser disks and be made available to physicians in any office with a personal computer.

Privacy in Space

Each astronaut will be assigned a sound-proofed compartment measuring about 4.2 cubic meters (150 cubic feet), which the astronaut can decorate according to his or her taste. In this nook, a little larger than a train berth, will be a TV set, a video playback unit, and stereo system; telephone and video links will permit private conversa-

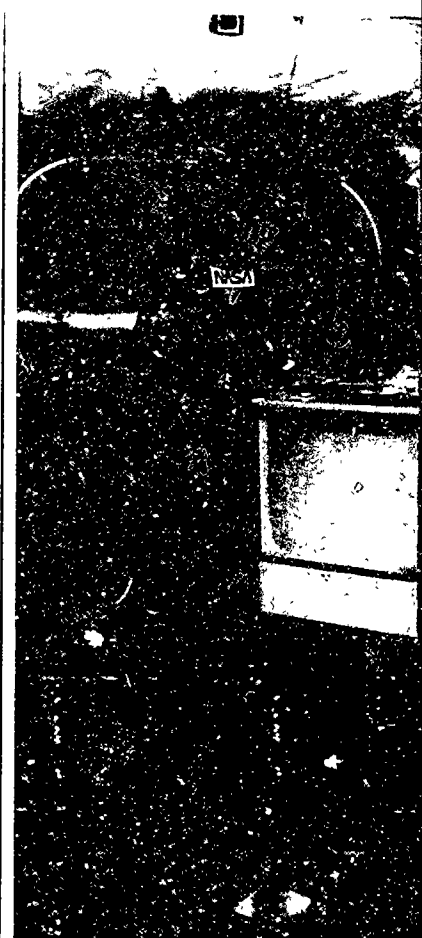

Multi-purpose activity table where crews will eat, work and relax is shown in module mockup at MSFC. Observation windows and video monitors will be located throughout Freedom's modules.

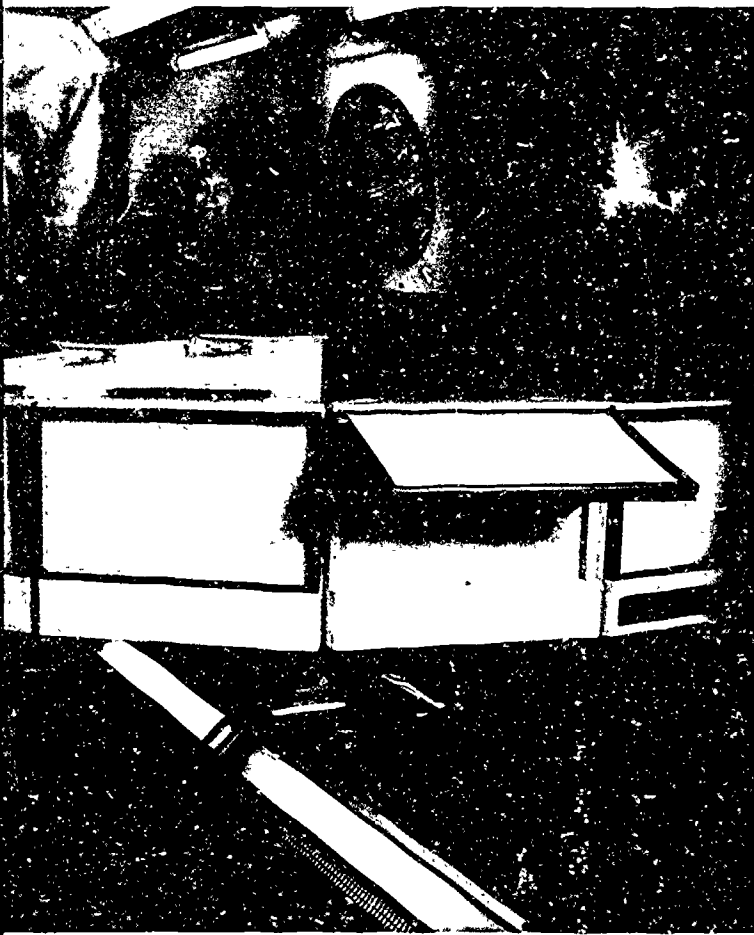

Earth observation window, shown here in habitation module mockup at JSC, would provide an ideal perspective of the world as well as possible view of exterior activities.

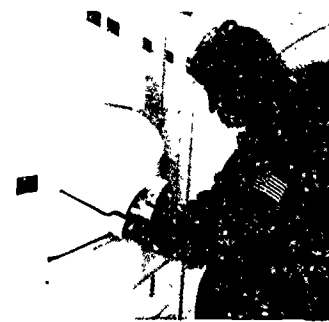

Washing hands in microgravity will be aided by this device now in development. Located in Freedom's galley area, the clam-shell type device also permits the scrubbing of utensils. (Courtesy of Boeing Aerospace)

tions with families and friends back on Earth. The private quarters will also be equipped with a computer terminal that the astronaut can use for entertainment, report writing, or simply updating a daily log.

A sleeping bag hung vertically on a wall will serve as the astronaut's bed. Once the astronaut climbs into the bag to go to sleep, elastic bands will roll up the zipper, imparting the feeling of a body lying horizontally on a bed.

Safety in Space

The concept of safe haven is incorporated in Freedom's design. Special circumstances — a fire or explosion within a module, a micrometeorite, or a chunk of space debris slicing through the Freedom's hull — could place crew members in jeopardy. At least two separate parts of the facility, therefore, will be designated as spots where crew members can gather to assess an emergency and then take appropriate action.

At present, NASA is examining emergencies aboard Freedom that do not fall within the capabilities of safety designs or the safe haven philosophy, such as an extended down time for the Shuttle, or a medical emergency onboard that cannot be treated in the HMF.

Over the next few years, NASA will examine the use of Crew Emergency Return Vehicles (CERVs), as well as alternatives for human transportation to and from Freedom. Under the CERV concept, a spacecraft would always be located at the manned base to evacuate crew members on a moment's notice and return them safely to Earth. A Space Shuttle, or some other type of manned vehicle that could be launched when needed, is also being examined.



Freedom's crew members will have individualized compartments located in the habitation module. Each of the private rooms will be outfitted with a TV set, stereo system and possibly a computer terminal for entertainment and work. Crew members will sleep in a bag hung vertically on the wall.

(Courtesy of Boeing Aerospace)



Mockup of the Health Maintenance Facility at JSC. This electronic version of a doctor's bag will help maintain the health and safety of the Station's crew.



Mockup of Freedom's galley, or kitchen, in JSC mockup of habitation module.

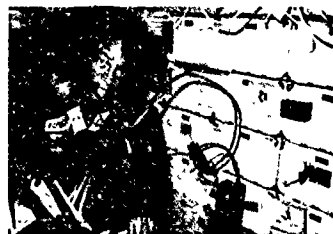

Exercise programs include use of a treadmill to avoid deconditioning of the cardiovascular system during extended stays in space. Here, astronaut Gulon Bluford runs on a treadmill during a 1983 Shuttle flight.



To supplement the Station's on-board safety features, NASA is examining concepts, such as the one shown here, for an emergency crew return vehicle.

DREAMS FULFILLED

or hundreds of years the idea of an orbiting facility in space has fueled the fantasies of writers, scientists, and engineers. Not until the great burst of scientific activity marking the turn of the 20th century, however, did the first truly thoughtful, provocative concepts for a space station emerge. Penned mostly by scientists and engineers, not one postulated a station in space as an end in itself.

Instead, the visionaries saw space stations as serving enduring purposes: enlarging our understanding of the cosmos, servicing Earth, and providing a way station to worlds beyond. In Russia, scientist Konstantin Tsiolkovsky clearly spelled out the possibility of orbital stations forming the heart of a program of space conquest that would eventually lead to "cities in space." To this day, Soviet exploits have kept alive Tsiolkovsky's assertion that "the planet is the cradle of mankind, but one cannot spend one's life in a cradle."

The Space Era is Launched

On October 4, 1957, when the Soviet's *Sputnik 1* rumbled skyward to give birth to the Space Age, the stuff of science fiction moved a notch closer to becoming science fact. With the creation of the National Aeronautics and Space Administration in 1958, American civilian space planning efforts were centralized, and the United States set out to become the lead space-faring nation in the

The Apollo program achieved the goal of landing a man on the Moon and returning him safely to Earth. Twelve men walked on the Moon during Apollo. One of the last to visit the Moon was Apollo 17 scientist-astronaut Harrison Schmitt shown here next to a deployed U.S. flag. The Earth, 240,000 miles away, is visible in the background.





2.4

Astronaut Edward White conducts the first American space walk June 1965 during a Gemini IV mission. Rendezvous and docking techniques, mandatory for the Apollo lunar landing effort, were developed during the Gemini program.



world. One year later, an embryonic space industry, coupled with NASA, began design studies of a manned space laboratory, soon to become popularly known as a space station.

The Challenge of Apollo

On May 25, 1961, President John F. Kennedy launched the Apollo program, calling on the nation to "commit itself to achieving the goal, before this decade is out, of landing a man on the Moon and returning him safely to Earth."

Kennedy's call also galvanized strong support for an Earth-orbit rendezvous,

that is, using a space station as a staging base for a flight to the Moon. As an added bonus, the station was to remain in place after the lunar landing. Within 10 years, every major new program being proposed for space was dependent on a space station.

Numerous designs were offered. They ranged from very large stations placed in orbit by giant boosters to inflatable balloon-like structures, retrofitted rocket stages, and canisters arranged in a spoke configuration that were then spun to create artificial gravity inside.

Eventually, limited funds and the President's deadline

led to an alternative approach for the Apollo program, a take off from Earth to be followed by a lunar orbit rendezvous, with one astronaut orbiting the Moon as two others landed on the Moon and explored it.

The Legacy of Skylab

Skylab was the first American experimental space station to be built, furnishing a wealth of experience between 1973 and 1974. Skylab achieved its fundamental objective, to determine human ability to adapt to prolonged weightlessness. Over 270 multidisciplinary investigations conducted by Skylab also provided un-

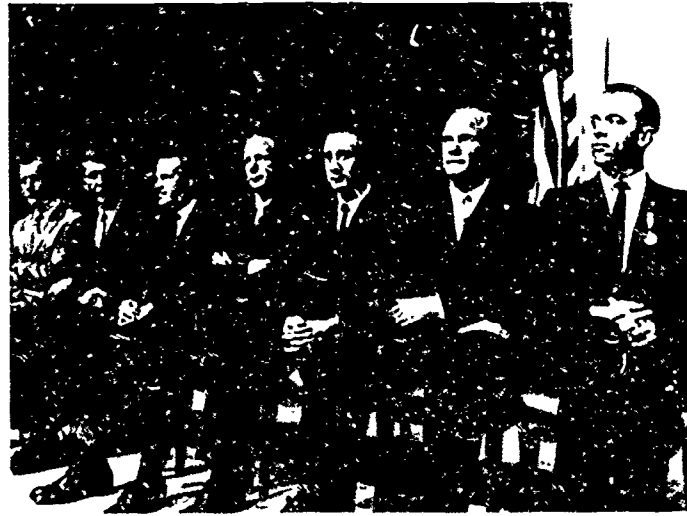

Original Mercury astronauts were announced on May 8, 1961. Left to right: Donald Slayton, Walter Schirra, Gordon Cooper, Scott Carpenter, Virgil Grissom, John Glenn and Alan Shepard.



Dr. Wernher von Braun contemplated use of large space stations in the 1950's to support exploratory treks to the Moon and to help send off spaceships to Mars.

precedented solar observations, Earth resource studies, and tests of space manufacturing techniques.

Far removed from the versatile Station now under way, this modest orbital workshop was actually a converted, left-over, Saturn V third stage used to launch the Apollo astronauts to the Moon. Astronauts were flown to and from the 91,000-kilogram (100 ton) orbiting laboratory, the size of a three-room house, in a small Apollo spacecraft, a transportation system limited to single up-and-down trips. To this day, Skylab's dimensions, which encompassed 353 cubic meters (12,700



An Atlas booster roars off its Florida launch pad carrying Scott Carpenter on Mercury-Atlas 9. The Mercury program opened wide the doors to space exploration by humans.

cubic feet) of work area along its 35-meter (117-foot) length, exceed those of any U.S. or Soviet manned spacecraft.

Skylab was not designed to support a permanent human presence in Earth orbit. During its lifetime, three separate teams of three astronauts each took up residence on Skylab for a total of 171 days, 13 hours, and 14 minutes, and took nine space walks totalling 41 hours, 46 minutes. They demonstrated that spending up to 84 days in space presented minimal physical or psychological problems. They also found that scientist-astronauts could function almost normally in a micro-gravity environment, working in tandem with ground scientists and performing major assembly and repair tasks.

The Next Logical Step

Subsequently, the inaugural flights of the Space Shuttle program showed that large structures could be built in space, with the Shuttle capable of ferrying the supplies and crew between Earth-orbit and Earth. Together with the Apollo and Skylab triumphs, all these space accomplishments gave credence to the words of America's rocket pioneer, Robert W. Goddard: "Real progress is not a leap in the dark, but a succession of logical steps."

On January 25, 1984, in his State-of-the-Union message, President Ronald Reagan committed the nation to building and inhabiting a space station. Reagan foresaw the space station as one way to stimulate quantum leaps in science, communications, and the development of new metals and pharmaceuticals. He also appealed to the best of our collective instincts, using the occasion to invite our allies to "help us meet these challenges and share in the benefits" posed by a

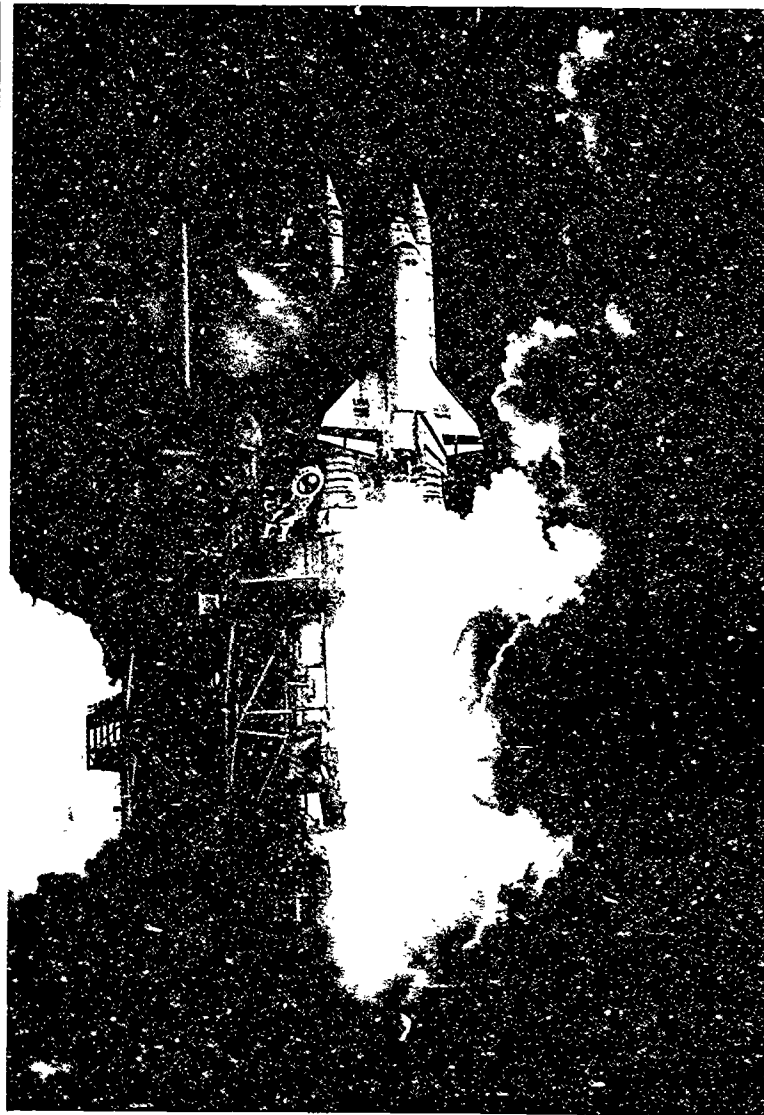

Manned access to space came of age with the reusable Space Shuttle. At the end of the Apollo program, NASA planners proposed developing the Shuttle and the Freedom as a matched pair, providing the necessary infrastructure to carry out ambitious manned and unmanned missions in the next century.

space station. This international invitation opened the way for other nations to share in the exciting scientific, technical, and commercially profitable enterprises that lie ahead.

NASA thereupon established internal task force teams, along with teams from major NASA contractors, to define the basic architecture of a space station. The first major studies led to several key decisions:

- A space station can be used as both a technological research center and a scientific laboratory.
- A space station can be

adapted to a wide array of space operations and missions, some foreseeable and others yet unknown.

- Reusable space transportation, such as the Space Shuttle, provides the essential means for trucking parts of a space station into space, and for rotating its crews and supplies.

- With a Space Shuttle in operation, we have a way to construct and add on to a space station in stages.

Power Towers and Dual Keels

One of the first good candidates for a space station configuration that could evolve over time came to be

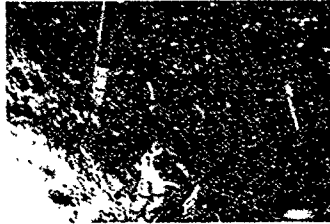

known as the "power tower." Its name matched its look: a girder 136 meters (450 feet) long that would circle the globe in a gravity-gradient attitude. Pressurized laboratory modules, service sheds, and docking ports were to be placed on the end always pointing downward; instruments for celestial observation would be mounted skyward, and the solar power arrays were to be mounted on a perpendicular boom, halfway up the tower.

After intensive review, the power tower was supplanted by a double truss, rectangular-shaped arrangement that shortened the height of the space station to 91 meters (300 feet). This "dual-keel" design made for a stronger frame, thus better dampening the oscillations expected during operations. The design also would move the laboratory modules to the station's center of gravity to allow public and private-sector scientists and materials-processing researchers to work near the quality microgravity zone in the station. Finally, the dual keel offered a far larger area for positioning facilities, attaching payloads, and storing supplies and parts.



Top: Astronauts will assemble the Freedom over the course of 20 separate Shuttle flights. Assembly concepts were demonstrated using experiments called EASE and ACCESS, which were assembled in space by Shuttle astronauts.

Above: In response to user needs, the dual keel configuration was adopted. It provided a better microgravity environment, structural stiffness and structure for attached payloads.

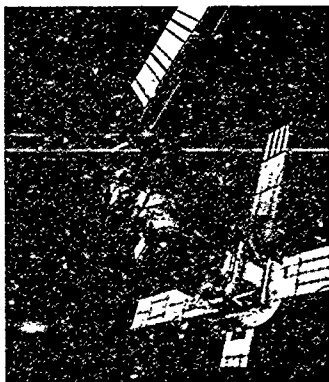

Skylab was America's first space station. Launched in 1973, the laboratory was visited by three separate teams of 3-man astronaut crews. Skylab supported solar and Earth investigations, materials processing experiments and proved humans could efficiently work and live in space for extended periods of time.



Astronauts Ed Gibson and Gerald Carr demonstrate weightless environment of space during Skylab mission.



A number of designs were evaluated before selecting the configuration of today. Among them, shown here, was the power tower.

BUILDING A WAY STATION TO WORLDS BEYOND

To maintain tight control over costs, engineers are taking an evolutionary approach to building Space Station Freedom. The baseline program includes the U.S. elements, international components, and two unmanned platforms. The next phase will bring in additional capabilities. Observers on the ground will witness the construction of Freedom as it grows from a small to a brilliant dot crossing the night sky.

The heart of Freedom's manned base will be a horizontal boom structure, 154 meters (508 feet) long. Four special-purpose modules — two U.S., one European, and one Japanese — will subsequently be attached to the boom at midpoint. Each module will have an atmosphere nearly identical to Earth's: 80 percent nitrogen and 20 percent oxygen kept at sea-level pressure. In these modules, eight men and women will superintend the space complex, perform experiments, maintain equipment, handle repairs, eat, sleep, and relax.

It will take 20 Shuttle trips over 3 years to assemble, outfit, and logistically support the manned base. Assembly of Space Station Freedom in orbit will be a challenge of enormous proportions, however the task will blaze the trail for ambitious missions in the future which will require on-orbit assembly, test, checkout and operation. Where possible, flight elements will

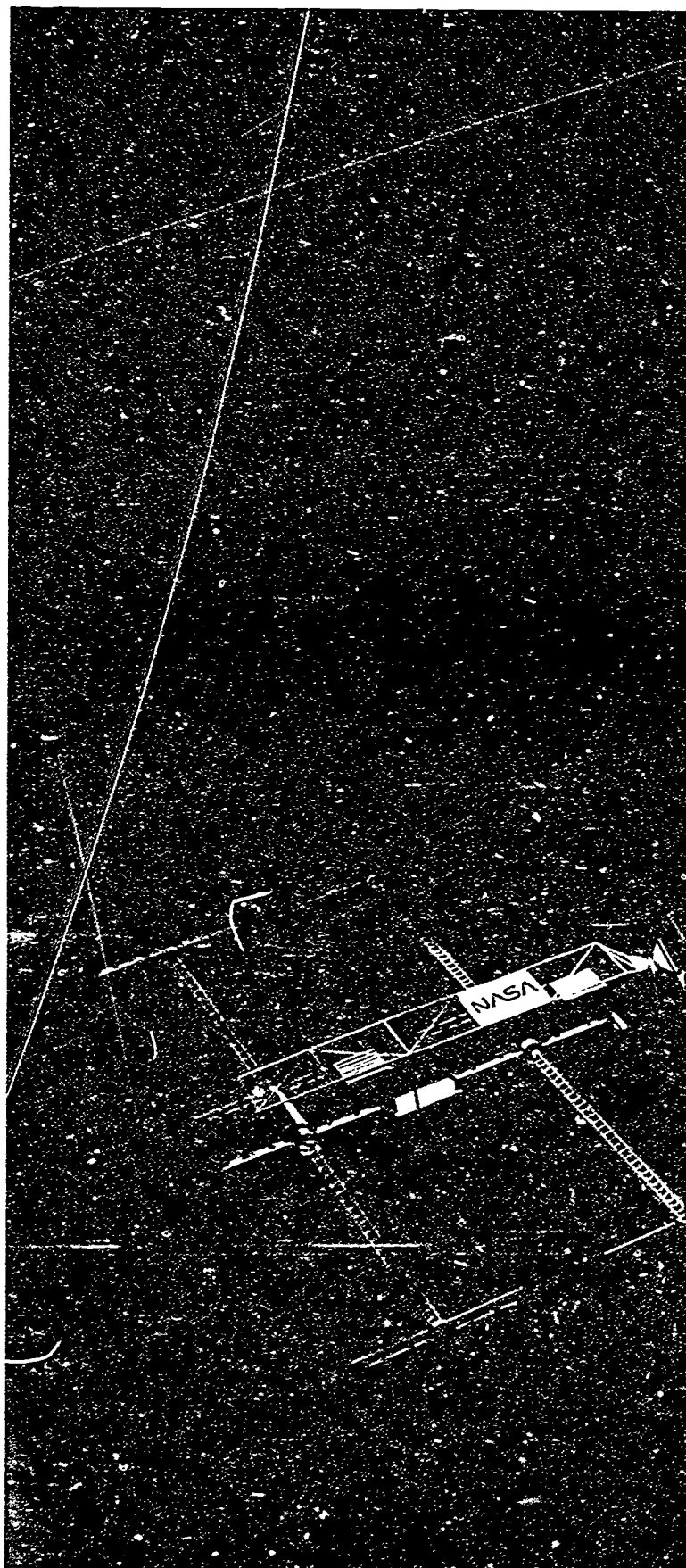

Freedom baseline configuration.

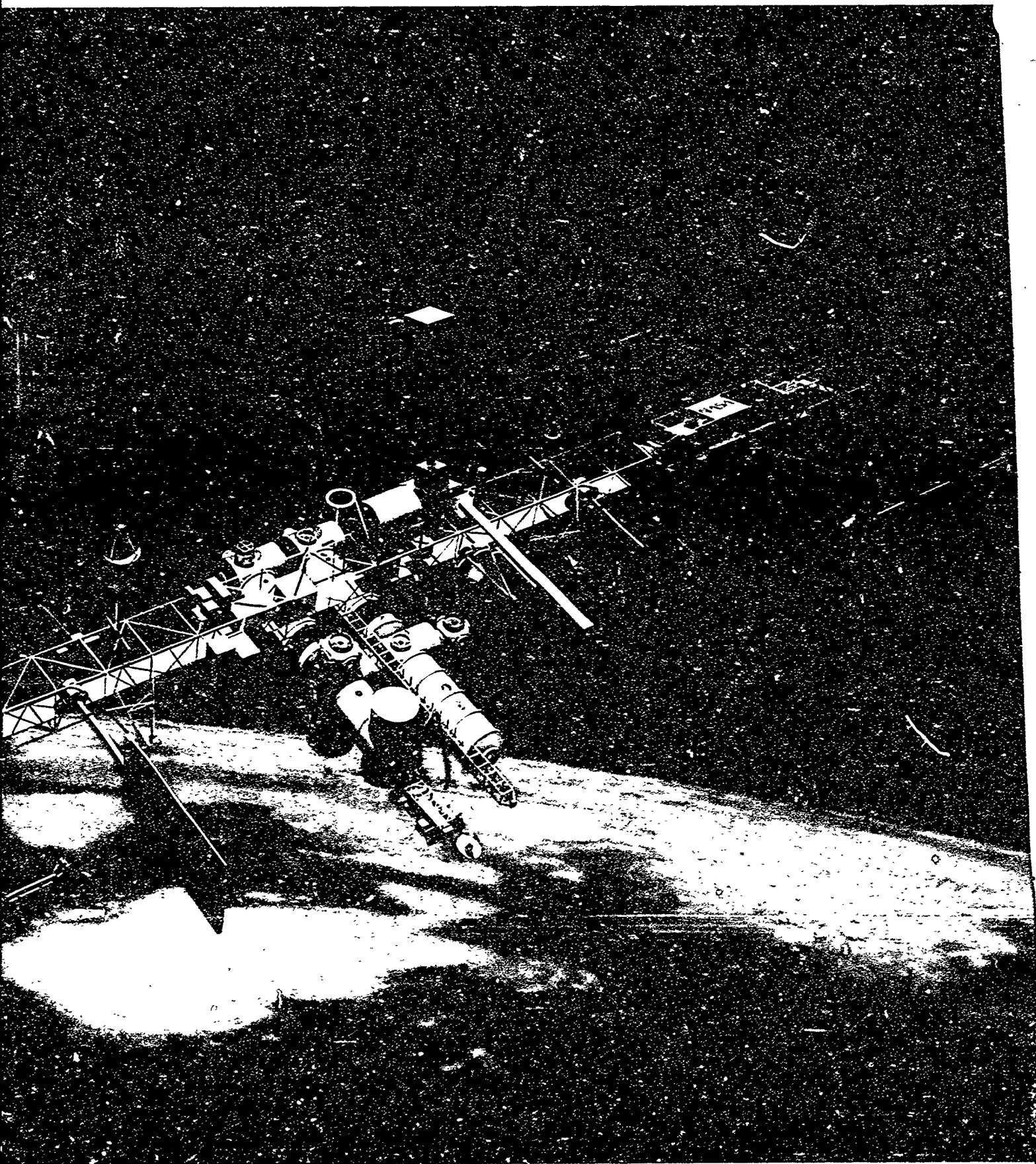

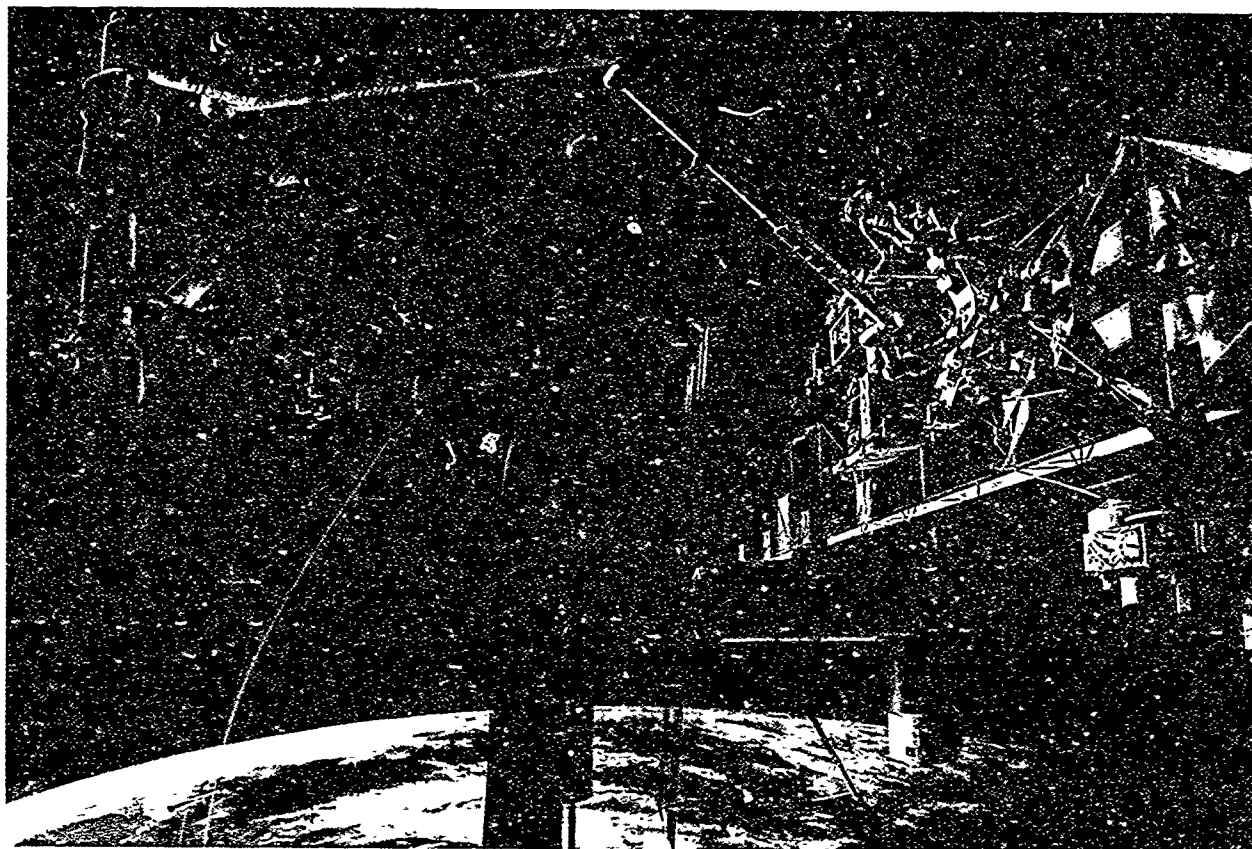

Canada's contribution to Freedom, the Mobile Servicing System, is essential in assembly, maintenance and servicing of Freedom's systems and payloads.

be fit checked on the ground before they are carried into orbit aboard the Shuttle. High-fidelity mockups and electronic simulators will be used to ensure the compatibility of elements that cannot be tested on the ground.

The first Shuttle flight carrying elements of Space Station Freedom will be launched into orbit about 1995 from the Kennedy Space Center in Florida. It will consist of a collection of linkable struts made of strong, yet lightweight composite material, one set of solar arrays and the necessary electronic components to make it capable of operating as a fully-functioning, independent spacecraft after the Shuttle has returned to Earth. During the flight, an astronaut construction team will piece the trusses together in Tinker-Toy fashion, and then deposit the assembled structure in space.

Other basic elements of Freedom, such as airlocks, the pressurized modules,

control systems, and remaining solar panels, will then be ferried up on subsequent flights. Once Freedom has been permanently occupied, logistics modules will be interchanged at regular intervals, approximately every other Shuttle flight, until the assembly task has been completed. These modules will serve as a delivery system and holding area for experiments, equipment, food, supplies, and propellants and other critical items needed to sustain Freedom and its crew.

Two polar platforms, one developed by the United States and the other by the European Space Agency, will also be boosted into orbit in the mid-1990s. The U.S. platform will be launched from the Vandenberg Western Test Range in California; the ESA platform will be lofted by France's Ariane rocket from Korou, French Guiana. The platforms will circle Earth from pole to pole. One will fly over the equator at the same

MILESTONE FLIGHTS



FIRST ELEMENT LAUNCH



MAN TENDED CAPABILITY



PERMANENTLY MANNED CAPABILITY

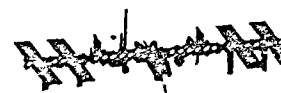

ASSEMBLY COMPLETE

Computer-drawn images of major milestones during the assembly of the Space Station Freedom.

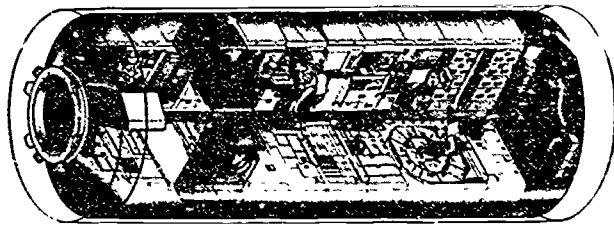

Interior concept of the laboratory modules where Freedom's crews will work. Crew members are shown working on a modular experiment rack, monitoring experiment status at a workstation, and installing biological samples into the floor-mounted centrifuge. *Illustration by NASA*

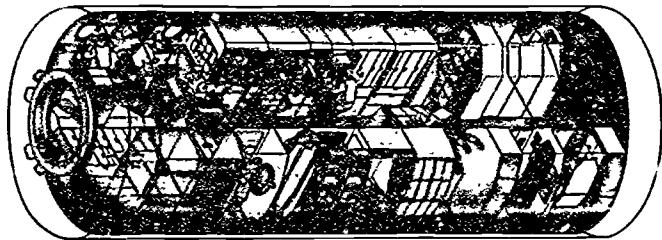

Interior concept of the habitation module. Galley and hygiene facilities are in forward end of the module, while individual crew compartments are toward the rear. *Illustration by NASA*

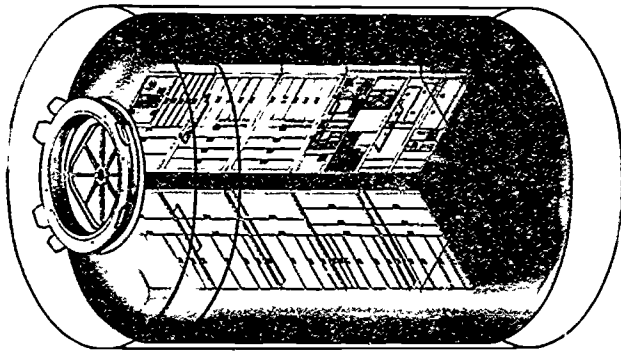

Logistics modules will be used to bring experiments, supplies and perishable items to the Station. *Illustration by NASA*

local time, morning and night, and the other will cross the equator at another local time, afternoon and night. Data collected by instruments aboard Freedom's unmanned Earth observers will enable scientists to study the intricate interaction of the oceans, land masses and atmosphere, and solar phenomena on our planet's environment.

During the early stages of assembly, a U.S. made Flight Telerobotic System will aid in the construction of the manned base. A Canadian built Mobile Servicing System (MSS), equipped

with a manipulator arm, will also be installed to assist in Freedom's assembly. The MSS is based on expertise acquired in creating Canadarm, the versatile robot arm used extensively in U.S. Space Shuttle missions. The MSS's robot arm will perform jobs controlled from work stations situated both inside and outside Freedom's pressurized modules. This arm will reduce the need for space walks, and eventually help deploy, dock, and redeploy a visiting Shuttle orbiter, assemble, retrieve, and transport payloads around the Freedom station,

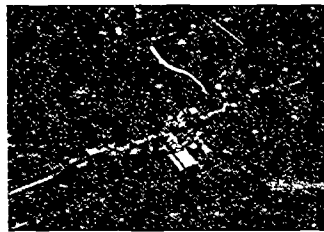

Growth phase of the Space Station Freedom, as currently envisioned by NASA, includes upper and lower keel structures, solar dynamic power keel system, a servicing bay and a co-orbiting unmanned platform (not shown). *Illustration by NASA*

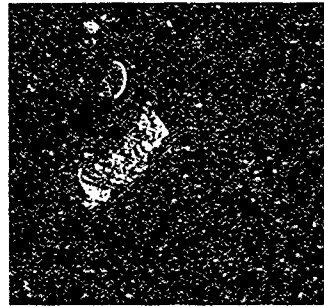

The U.S. polar-orbiting unmanned platform is an integral part of the Freedom program. The free flyer will carry a variety of Earth observation instruments as part of an extensive program to study the Earth as a system. *Illustration by NASA*

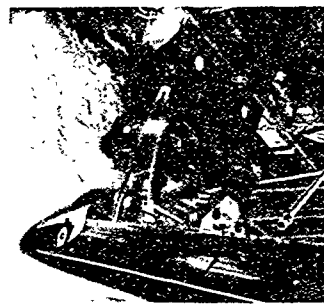

Close-up artist's concept of a Shuttle orbiter docked to the Freedom. Canadian robot arm is shown on mobile base. Sky-viewing instruments are mounted on a pallet-structure situated on the upper face of the Station's truss. *Illustration by NASA*

and position astronauts for access to its various parts. Mounted atop a NASA built flatcar, to be developed in a future phase of the Freedom program, the MSS will be able to move along Freedom's extensive truss structure.

Two of the pressurized modules that will be attached to the horizontal boom are being supplied by the United States. One will serve as a laboratory, the other as a living area. Each module will be taken up individually into space inside the Shuttle's cargo bay. Astronauts, assisted by the manipulator arm, will remove the modules from the Shuttle and secure them in their proper locations on the Freedom station's trusswork.

Each U.S. module is nearly 13.6 meters (45 feet) long and about 4.5 meters (15 feet) in diameter. Early in the assembly sequence, the laboratory module will be positioned on Freedom's supporting frame. With this

first module in place, astronauts can start equipping the laboratory with early experiments while the Shuttle is docked, periods which could extend from two weeks to a month. A Space Shuttle will deposit the habitation module at the orbiting construction site several flights later. With the addition of the forward nodes and logistics module, Freedom will be ready for permanent occupation.

The Japanese and European modules, slightly smaller than their American counterparts, are scheduled to arrive, respectively, after Freedom is permanently sited. The Japanese Experimental Module (JEM) will accommodate scientific and technological development research, including microgravity experiments. A space-exposed deck will hold a variety of experiments that can be reached by a manipulator arm. The JEM will include a detachable, experiment logistics module that

would hold consumable goods, experimental specimens, and various kinds of gases for the Japanese Experiment Module. This logistics cannister can be hauled into orbit aboard the Shuttle, or by a Japanese expendable launch vehicle which will be operational by the mid-1990s.

ESA's design for a permanently attached laboratory module is based on Spacelab, its contribution to the Space Shuttle program. Spacelab has successfully flown several times in the cargo bay of a Space Shuttle. Derived from that design, the ESA module will consist of four cylindrical segments forming a pressurized module. Once it is permanently attached, the ESA laboratory module will become a research site for crews to perform experiments in the physics of fluids, life sciences, and materials research. At that point, the basic foundation for living, working, and studying aboard Space Station Freedom will be in place.

ESA is also developing, as part of its contribution to Space Station Freedom, a Man-Tended Free Flyer (MTFF) to be made up of two Spacelab segments and a resource module that holds supplies. The MTFF will function independently of the manned base.

As a self-contained automatic laboratory circling Earth, this spacecraft could produce space-grown crystals and other specialized materials in an undisturbed environment. Exchanging the harvest of MTFF-produced products with raw stock would be handled by Freedom's crew, Space Shuttle astronauts, or the crew of the European space plane Hermes, now under development.

Freedom's crew members will move between the various modules through four interconnecting resource nodes, or sets of pressurized cylinders. The



Mockup of cupola, which will give astronauts a panoramic view for scientific and operational observations. (Courtesy of McDonnell-Douglas)



The Shuttle, as it might appear preparing to dock with the Freedom, provides the means to incrementally construct the facility, resupply it and rotate its onboard researchers.

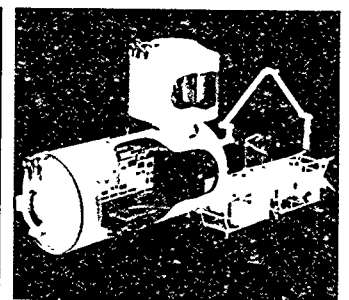

Detailed model of the Japanese Experiment Module. The JEM features a pressurized laboratory module, exposed workdeck and robot arm. The smaller module on top is an experiment logistics module.

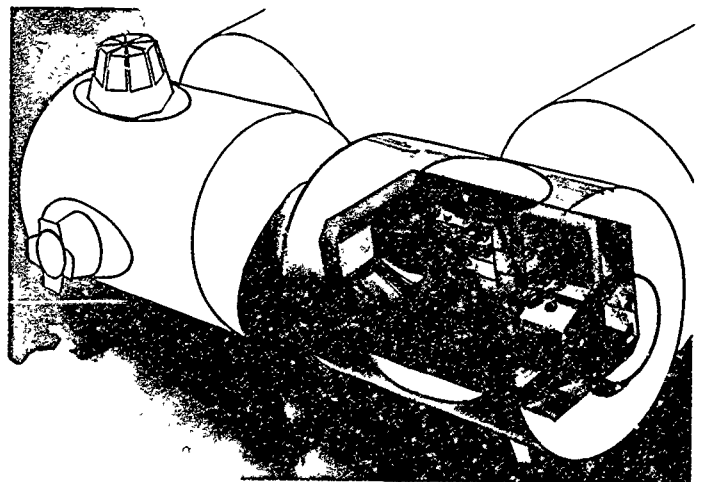

Freedom resource nodes will connect the habitat and laboratory modules. (Courtesy of McDonnell-Douglas)

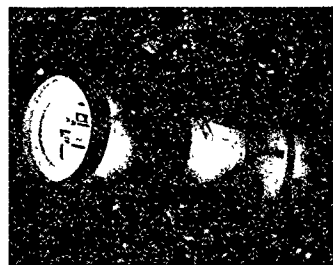

ESA is providing several elements to the Freedom program, including a permanently-attached laboratory module like the one shown here.



Artist's concept of Freedom baseline configuration.

nodes are spacious and outfitted with command stations, control-work stations, and other hardware. The forward nodes will contain the primary and backup docking ports for Shuttle orbiters.

Two nodes are fitted with airlocks through which astronauts can leave for work outside Freedom's pressurized modules. The forward nodes are sure to be a favorite lookout point. With two windowed cupolas, one looking toward Earth and the other looking outward to space, they offer on-top-of-the-world sightseeing at its best. The panoramic view of all space above and below the manned base will permit astronauts to monitor an incoming Shuttle, guide robot arms performing external payload assembly or maintenance tasks, conduct scientific observations, and observe fellow crew members on EVAs.

Electric power for Freedom's manned base will come from arrays of solar

cells, which are deployed from the power modules located on the ends of the horizontal boom. The four outstretched solar arrays at each end of the boom contain a total of about a half acre of solar cells. The solar arrays provide all the power needs during the sunlit portions of an orbit. In addition, they provide electric power to charge batteries which then provide all the power needs during the dark portions of each orbit. Together, the solar arrays and batteries will be able to provide 75,000 watts of electricity, enough to power about 25 all-electric homes on Earth. The largest electric power level required in space to date, it will support all the housekeeping loads as well as the power needs of scientific equipment, computers, communications equipment, and equipment such as materials-processing furnaces.

Regular visits to Freedom by the Space Shuttle will bring new crew members,

visiting scientists and a logistics module, loaded with new supplies, to exchange with the logistics module already in place. To further sustain the Freedom station with new supplies and experiments, unmanned rockets, possibly including Japanese or European boosters, may also be commissioned.

Recently, with their space laboratory Mir, the Soviets have shown that humans can live and work in space for almost a year without the benefit of artificial gravity. NASA plans to have the crew members serve tours of duty on Freedom that will gradually expand from 90 to 180 days as more is learned about the physiological effects of prolonged weightlessness.

Space Station Freedom, which NASA and its partners will assemble in space, will be much more than a collection of Earth-circling girders and cylinders housing hard-working astronauts and scientists. It is also a commitment to the bold pursuit of scientific knowledge, technological prowess, and new commerce — all ingredients essential to meeting the demands and opportunities of the 21st century.

ORBITAL MECHANICS

The impact of a permanently occupied space station will be felt from its ability to support the servicing of scientific platforms and satellites in space. The first on-orbit repair took place in 1972 during the Skylab program. Even more ambitious missions have been accomplished from the Shuttle. The Leasat communications satellite and the scientific Sun watcher, Solar Max were also repaired in orbit and put back into service.

As a result, new generations of spacecraft are being built specifically for space tune-up and changeout. Carrying critical, replaceable hardware, they include the great observatories — the Hubble Space Telescope, the Gamma Ray Observatory, the Advanced X-Ray Astrophysics Facility, and the Space Infrared Telescope Facility — all expensive eyes on the universe being readied for operation over extended lifetimes.

In time, astronauts controlling a Freedom-based unmanned robotic tugboat, called an Orbital Maneuvering Vehicle (OMV), will be able to retrieve spacecraft from over a thousand miles away. Once the spacecraft is retrieved, a space-suited crew will replenish fuels and vital liquids, and overhaul, add to, and adjust equipment on the spacecraft. Space assets which may benefit from this capability range from scientific instruments fixed to Freedom's trusswork, to unmanned materials processing platforms orbiting within range of the manned base, to the large astronomical

Artist's concept of the Hubble Space Telescope after deployment from the Shuttle. The HST, as well as other large astronomic facilities, are candidates for on-orbit servicing supported by Freedom.



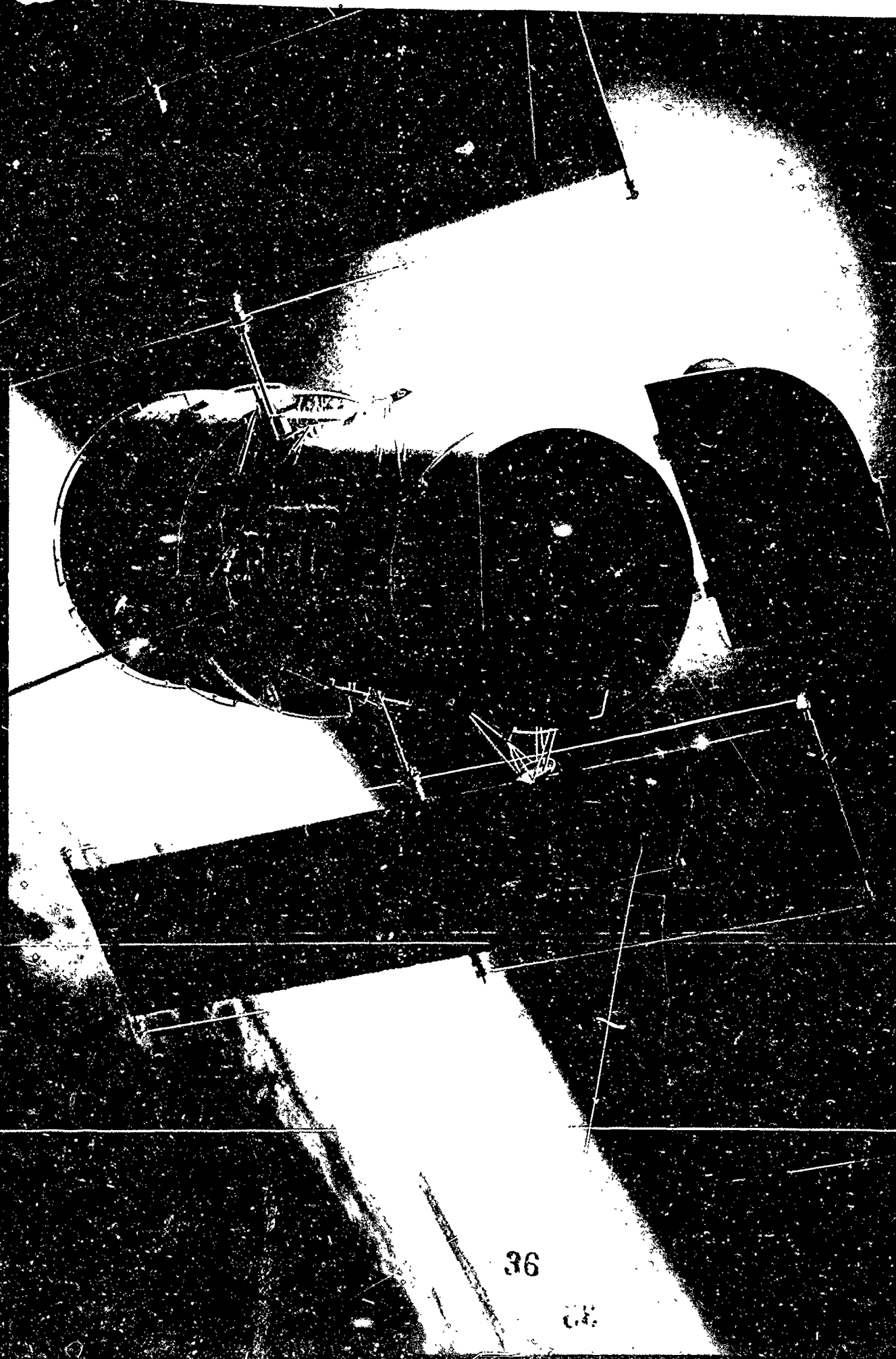

36

04

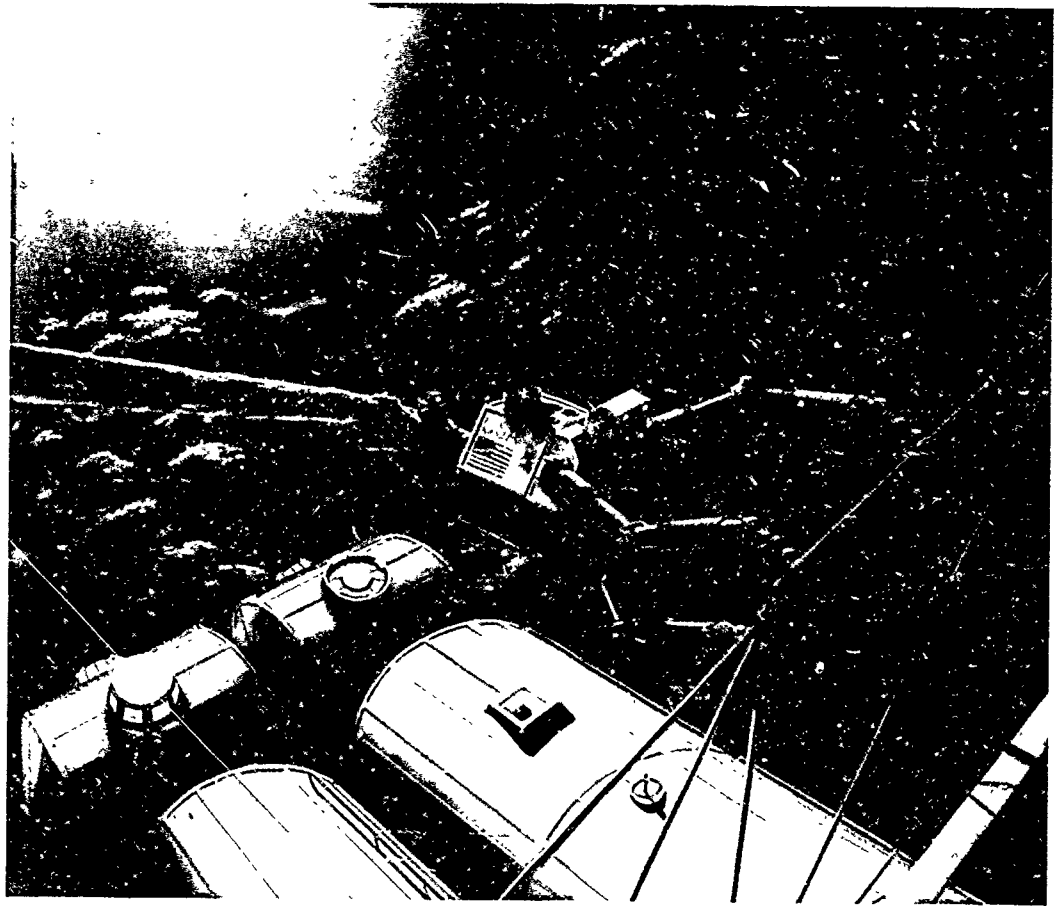

The multi armed Flight Telerobotic Servicer will be used to assist astronauts in the assembly of Freedom, and will help maintain scientific instruments located on the complex.

observatories planned for development in the coming decade.

If a small component fetched from a disabled spacecraft requires detailed work, astronauts will carry it into one of Freedom's laboratory modules via an airlock. Then, in the comfort of a shirt sleeve atmosphere, a crew member sitting at a work bench will solder, test, or changeout printed circuit boards. The versatile OMV will then propel the overhauled spacecraft back into orbit.

Freedom's crew will also be able to perform repairs in space, positioning themselves and the satellites they are servicing in limitless orientations. Indeed, with appropriate tools and restraints, human beings can sometimes work as effectively in space as on Earth. Special spacesuits, easy to maintain on board the Freedom station, are therefore being designed to

endure from 2000 to 3000 hours of extravehicular activity (EVA) a year, ten times longer than all EVAs conducted to date. Once inside the high pressure suit, an astronaut can move in and out of space rapidly without the time consuming pre-breathing session currently required to rid the blood stream of nitrogen when shifting from a high to a low pressure environment.

Supplementing Human Ingenuity

Automation and robotic applications can provide reliability, precision, and a tireless capacity to perform routine, repetitive, and sometimes high risk tasks. Past space exploits, however, show that human ingenuity is necessary to evaluate a situation, develop a course of action, and implement a plan. Often such human intervention has made the difference between the failure

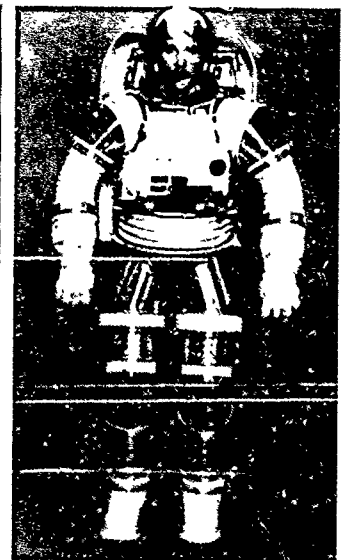

High-pressure space suits, such as this one, are under study for use on Freedom where EVAs will be a routine practice. The Zero Prebreath Suit allows astronauts to avoid extensive depressurization period required when going out in space with current Shuttle-based suits.

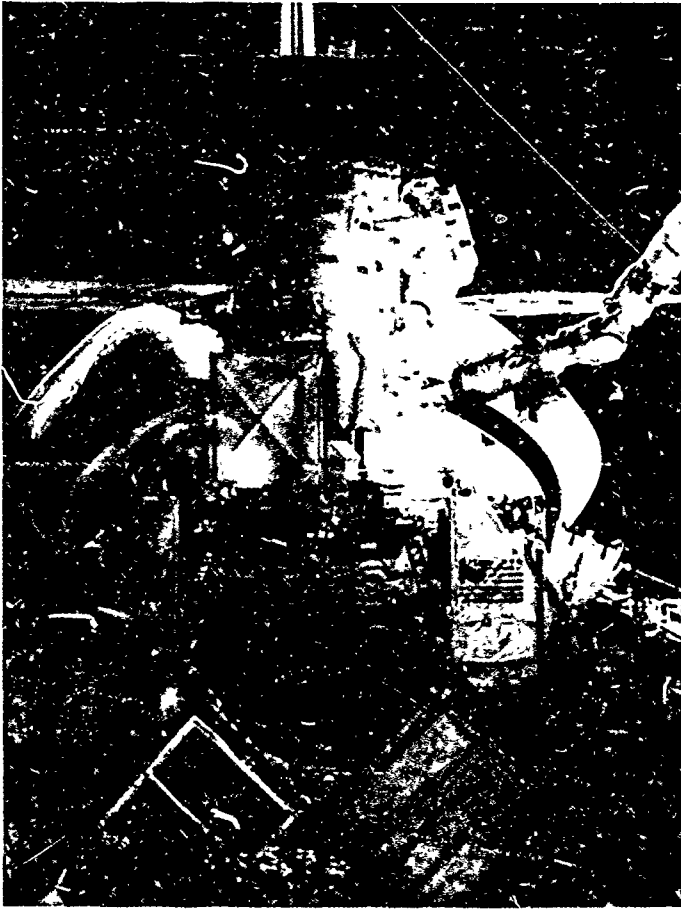

Maintenance and repair of Earth-orbiting satellites has been demonstrated on Shuttle flights, such as the Solar Max repair mission. Freedom will also be capable of maintaining, upgrading and repairing space assets, thus extending their value and productivity.

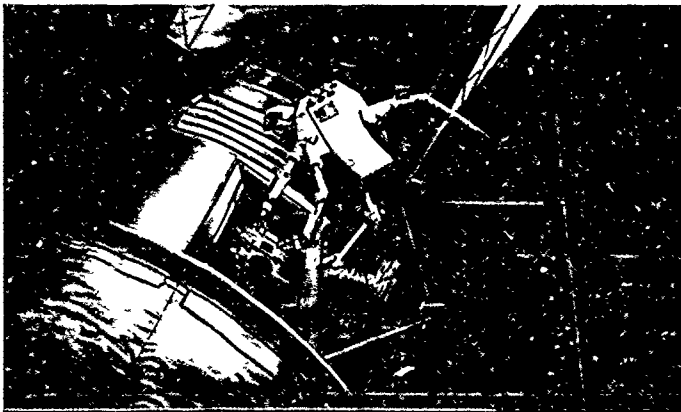

Robots, like the FTS, will perform high-risk tasks like satellite repair, shown here, or spacecraft refueling, under remote control of Freedom's crew members.

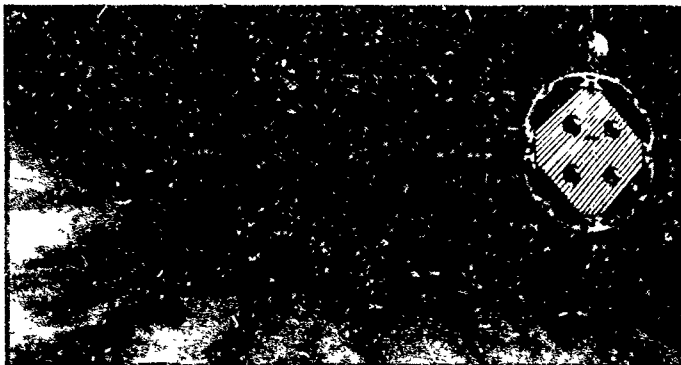

An Orbital Maneuvering Vehicle prepares to dock with the HST. In the distance is an enhanced configuration for Freedom where maintenance will be performed.

and success of a mission.

In 1984, Congress directed NASA to study the job of melding human and machine proficiency in the service of the national space effort. The congressional directive has begun to produce exciting results. While still a far cry from those lovable science fiction robots, C3PO and R2 D2, the Flight Telerobotic System (FTS), has become an integral part of the Freedom program. The space robot can be controlled by an operator on the Freedom station or on the ground. It will ultimately have the work capability of a space-suited astronaut and will help in the on orbit assembly and maintenance of the manned base, thus minimizing the amount of human extravehicular activity and the risk involved.

Advanced telerobots, equipped with sophisticated, finger like manipulators approaching human dexterity, would be able to perform such sensitive, specialized tasks as servicing parts of Freedom or refueling a spacecraft. Advances in computer vision with voice command links will also allow robots to serve as "go fers." Think for yourself automatons also are expected to come out of NASA's automation and robotics programs.

Other early goals include automating the guidance, control, and navigation functions. Study is also underway on lessening the astronauts' workload by using artificial intelligence (AI) to control and monitor temperature and electrical power distribution, warn of potential hardware failure, and keep inventories of tools, equipment, clothes, and food. Spaceborne AI technology could also network many of these jobs so they talk to each other; by making use of expert systems, they can also infer, reason, learn, and act appropriately.

EVOLVING WITH VERSATILITY

reliminary work aboard Freedom is expected to stimulate still more uses. Space Station Freedom, therefore, is being attuned to a philosophy of adaptability and change. Its design, for example, features "hooks and scars," electronic and mechanical interfaces that allow Freedom's designers to expand capability. In this way, new and upgraded components, such as computer hardware, data management software, and power systems, can be installed easily. The concept is similar to buying a home prewired for eventual hookup to a TV cable system even though the cable company has not yet reached your area.

Adding On

Engineers have also blueprinted a configuration for expanding Freedom that builds on the initial structure. In this advanced version, two 103 meter (340 foot) long vertical spines will connect with the horizontal cross boom. With a near rectangular shape comparable in size to a football field, the frame will be much stiffer and also allow ample room for a bevy of new payloads.

On the upper beam, for example, cosmic ray experiments, solar and astrometric telescopes and related detectors, solar cell and spacecraft materials, and coating studies can be exposed to the environs of space. To boost electricity levels, a pair of solar dynamic generators featuring reflecting mirrors can also be

A Freedom-based Orbital Transfer Vehicle could be assembled, serviced and fueled at the complex. The OTV could propel astronauts and hardware to high Earth orbits or exploratory targets. The umbrella-like structure is used for aerobraking.



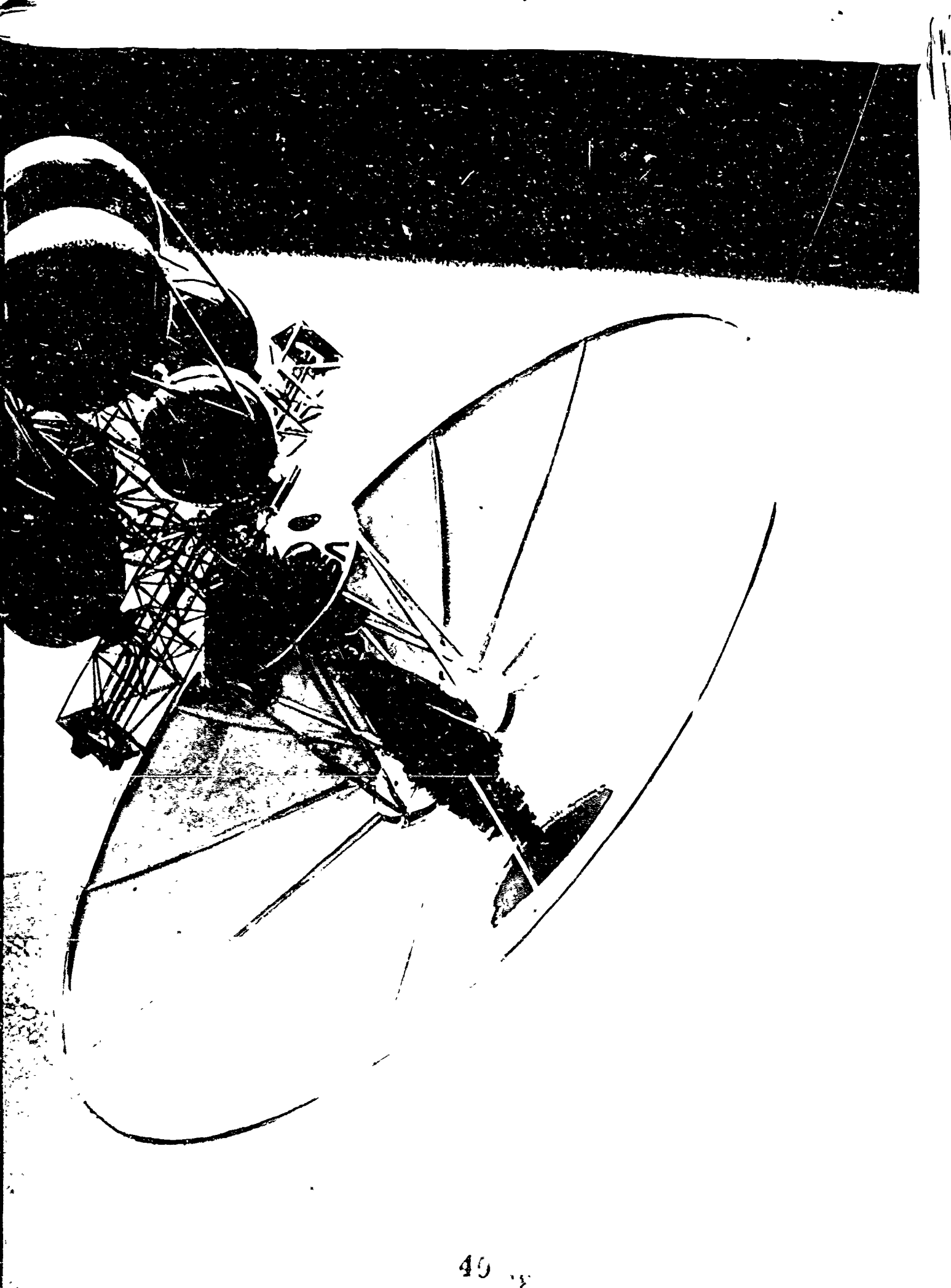

attached to the structure. Collecting heat from the intense rays of the Sun, parabolic mirror segments will focus this energy on a fluid which then drives a turbine engine that generates electricity, supplementing Freedom's power by another 50,000 watts.

Also envisioned as part of the enhanced Freedom are unmanned co-orbiting platforms. Such platforms could be equipped with large antennas that scan the universe for radio chatter from distant communities. Or, they might focus on astrophysics research, solar observation, or a wide variety of Earth-oriented or astronomical endeavors.

A large servicing bay, 60 meters (200 feet) long and nearly 30 meters (100 feet) across, to house an entire "great observatory" spacecraft, also is planned on the enhanced Freedom. Once an observatory is parked inside the cavernous hangar, astronauts could easily align, clean, and even recoat astronomical instruments in a pressurized environment, leaving their cumbersome spacewalking suits on the rack.

Another evolutionary path for Space Station Freedom calls for added reliance on automation and robotics, particularly for building sizable structures in Earth orbit. Such space structures will be able to accommodate large cargoes of equipment, fuel, and other materials that can perpetuate Freedom's growth and use.

Other growth scenarios might include attached modules to hold plants grown in space as part of a closed ecological life-support study, or which serve as a quarantine area for studying precious samples of comets or Martian soil brought to Freedom by robotic spacecraft. A module could also become a biomedical study center assigned the duty of developing and evaluating

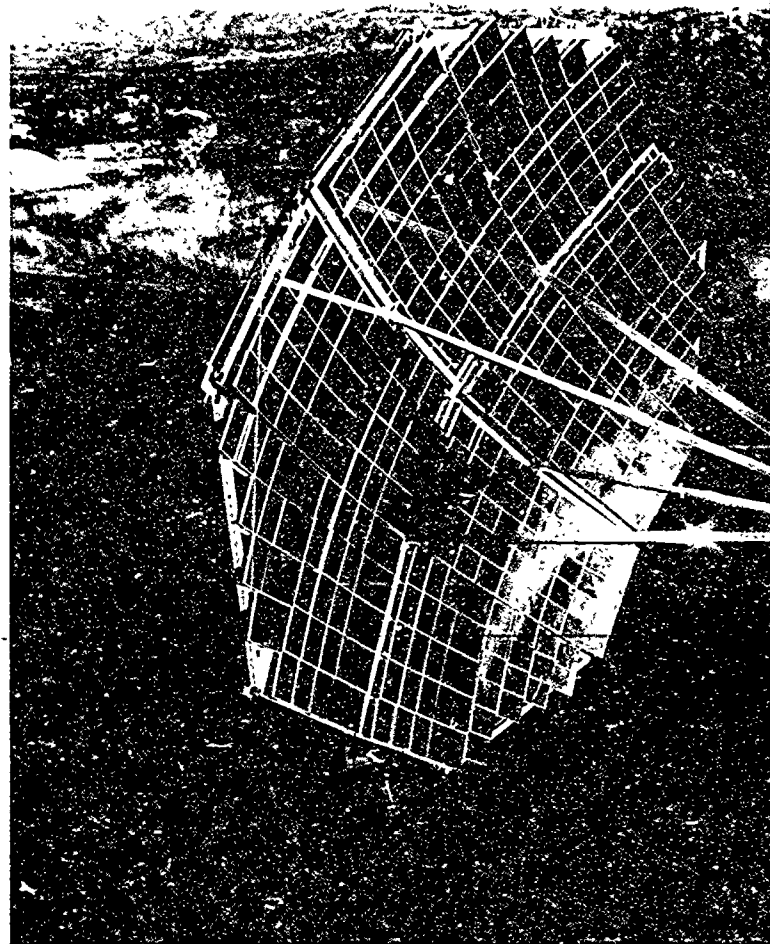

Rocketdyne, NASA's contractor for the Station's power system, has developed a functioning prototype of the solar dynamic power system which is expected to furnish additional power for the Station in the future.

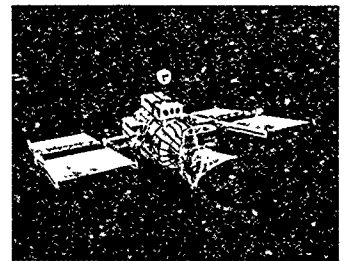

Future unmanned spacecraft, designed for on-orbit servicing from the Freedom, include the Advanced X-Ray Astronomy Facility and

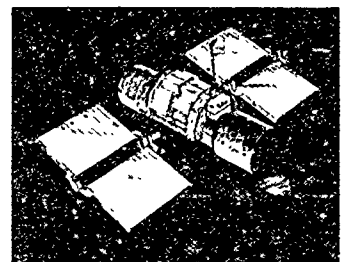

the Space Infrared Telescope Facility. These spacecraft would be placed in an orbit near the Station where crews can periodically exchange and update scientific instruments.

(Images courtesy of GE Aerospace)

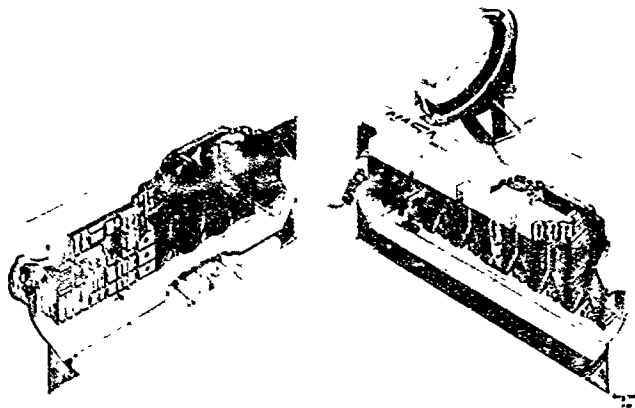

With an eye toward future self-sufficiency on the Moon or Mars, a potential future module could serve as a space garden, as shown in this artist's concept. Robots would tend the garden which would supply food for the astronauts.

Courtesy: NASA

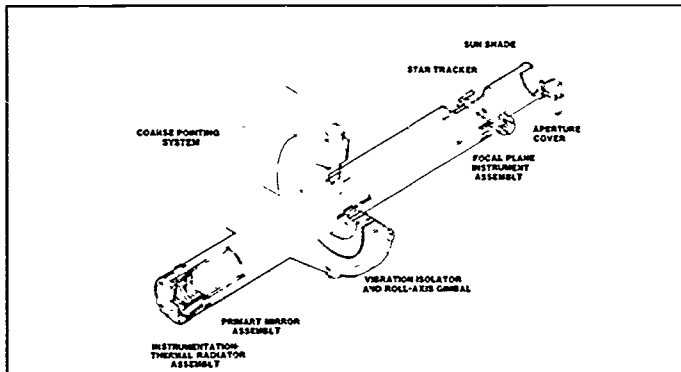

Astrometric Telescope Facility, which would search for planetary systems around other stars, could operate as an attached payload on Freedom's upper keel.

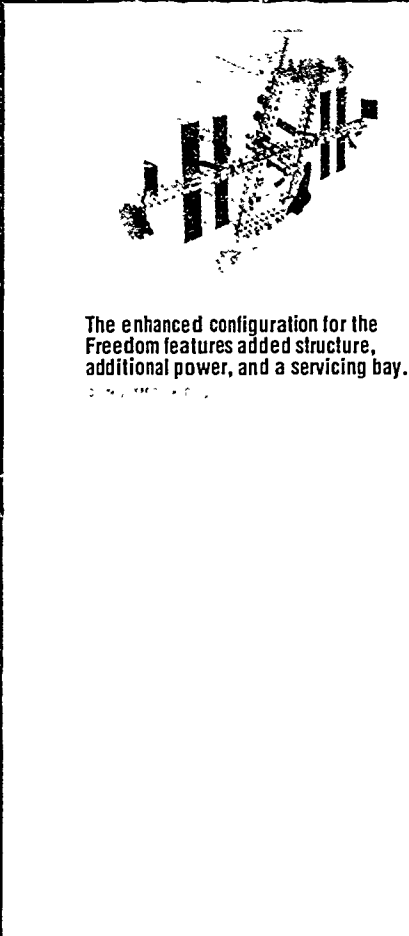

The enhanced configuration for the Freedom features added structure, additional power, and a servicing bay.

countermeasures to the effects of microgravity on humans.

Branching Out

NASA calls it "branching" — a Freedom-based activity so fruitful that it can branch off into its own facility. A common branching concept calls for a human-tended facility where made-in-space products, such as rare metals, glasses, and electronic material, can be processed in an absolutely vibration-free environment. This research base could even lead to another branching financed by a high-tech industry that wants its own production facility in space.

As little as scientists know about human adaptation to microgravity, even less is known about the long-term effects of exposure to the one-sixth gravity of the Moon or the one-third gravity of Mars. One suggestion, therefore, is to

develop a facility, capable of simulating different artificial gravity conditions, using Freedom's components. The facility would consist of a module connected to a counterweight at the end of a long tether. Capable of rotating at different rates, thereby yielding different artificial conditions, this free-flying variable gravity research facility could lead to new biomedical data necessary to "flight quality" humans for journeys to worlds beyond the Earth.

Another branching candidate is a shipyard in orbit. This depot could act as an assembly, service, and fueling spot for a host of space vehicles. An Orbital Transfer Vehicle (OTV) stationed at Freedom, could be used for propelling astronauts and hardware to orbits higher than the manned base's operating altitude, even to geostationary orbit, or the Moon.

FOOTHOLD ON THE FUTURE

Freedom's permanency and its mix of human aptitudes and technologies will add an extraordinary dimension to the achievement of long-term space goals. An ideal focal point for collecting performance data on space technologies, Freedom will, for example, accommodate the assembly and testing of antennas too large or too fragile to assemble on or launch from Earth.

Fluid management technology can also be enhanced through testing on Freedom. Knowing how to safely store and transfer fuels in microgravity is a prerequisite to establishing large fuel depots in orbit. Advanced spacecraft materials and coatings that are eventually to be used in optical detectors, mirrors, and solar cells can be proofed by exposure to the space environment. Long-term effects of atomic oxygen and a near vacuum, including bombardment by ultraviolet rays, electrons, and protons, can also be studied.

High-power energy systems, laser-communication equipment, advanced life-support concepts, complex automation and robotic hardware, new propulsion systems—technologies which are pivotal to enlarging the sphere of space operations above Earth—all can benefit from preliminary assessment in orbit. Taking advantage of Freedom's capability to test before tasking will multiply the accomplishments of the civilian space program over the coming decades.

A Framework for Tomorrow

In a 1987 report to NASA Administrator James Fletcher, a task force led by Dr. Sally Ride, America's first woman in space, concluded

that the nation will be able to regain and retain leadership in space only if it has "a clear strategy in place, and its goals for the future defined and developed." The report goes on to state that future space scenarios depend on the research, hardware development, and successful use of automation, robotics, and other technologies and abilities gleaned from Space Station Freedom.

According to the study, four initiatives provide a framework for the future:

- Expanded studies of Earth that characterize our home planet on a global scale.
- An enhanced program of Solar System exploration using robots.
- Establishment of a permanent outpost on the Moon that builds on the Apollo program.
- A program to send humans to Mars, leading to the eventual establishment of a permanent Martian base.

The report also included a scenario for a human return to the Moon by the year 2000, followed in five years by an outpost 384,500 kilometers (240,000 miles) away on the Moon and sheltering five astronauts for several weeks at a time. Circa 2010, up to thirty lunar explorers can be working at the outpost over a period of months. This lunar initiative, concludes the study, will nurture the experience, expertise, and confidence needed to commit the Nation to an astronaut outpost on Mars 320 million kilometers (200 million miles away) by the year 2010.

The National Commission on Space determined a settlement on Mars in the 21st century could be achieved. The first steps toward expanding human life to such distances begins with Space Station Freedom.





Freedom will support technology development and buildup of vehicles, such as this Cargo Vehicle Propulsion element, for use in a piloted Mars mission and out-planet robotic exploration missions.

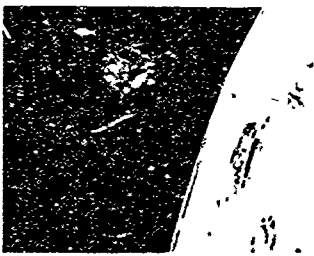
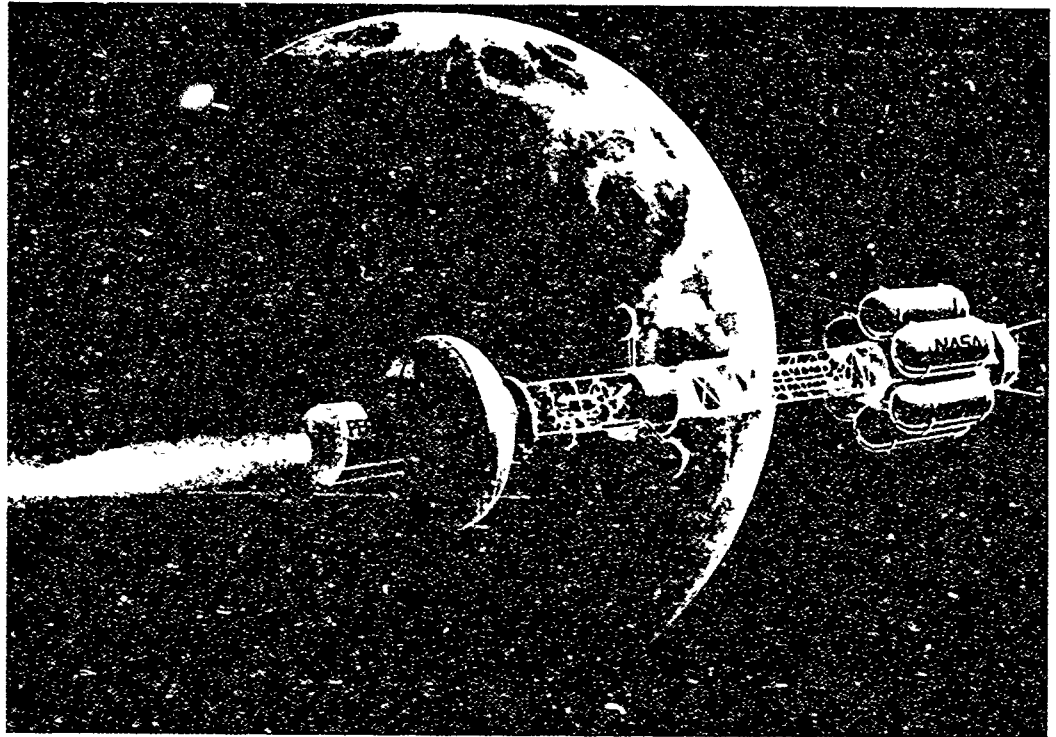

Mars Observer, scheduled for launch in 1992, is designed to follow up on knowledge gained from Mariner and Viking missions to the planet, and serve as a precursor for future Mars exploratory missions.

However, concludes the report, "Until the Space Station is occupied and actual long-duration testing is begun, we will lack the knowledge necessary to design and conduct interplanetary flights or to inhabit lower-gravity surface bases."

Similar goals were championed in a 1986 report to President Reagan from the National Commission on Space. This blue-ribbon group noted that the movement of human life outside Earth requires the development of a space station. Over time, the space station will evolve into an "earth spaceport," serving as a hub for both unpiloted and human traffic. This economic transfer of passengers and vehicles with Earth would lay the ground, so to speak, for a "highway to space" as well as a "bridge between worlds," initially to the Moon and subsequently to Mars.

Humans living along this space frontier, hypothesizes the Commission, would live off the land, deriving energy and materials from planet-circling moons, asteroids, and planetary surfaces as they

make their way through the Solar System. Indeed, as the Solar System becomes humanity's extended home, the umbilical to Earth could eventually be cut.

Certainly, there is no question that visioneering is alive, well, and running on

full throttle in the United States. Indeed, that recovery process is predicated in good measure on pressing forward to a new future in space — a future symbolized by Space Station Freedom, our foothold on the future.

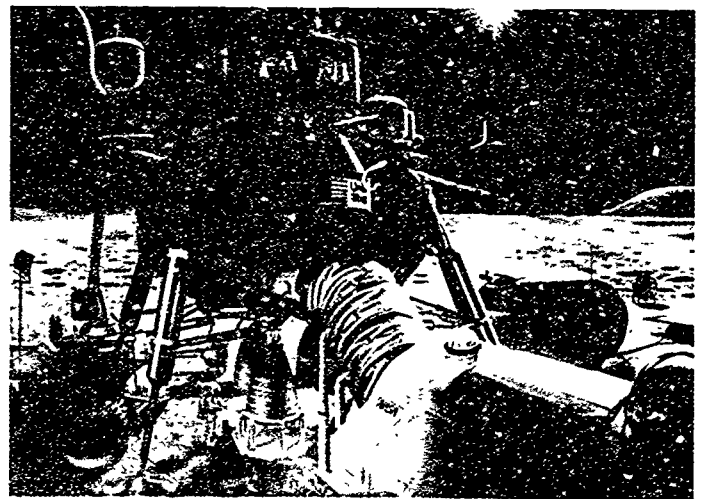

Permanent outposts on the Moon, building on the success of Apollo, have been proposed as a future space goal.



A future program to send humans to Mars could involve hardware depicted in this artist's concept.



Freedom will support development and flight-testing of advanced Earth-orbit technologies developed under NASA's Pathfinder project.



Samples, collected during unmanned missions to Mars, could be brought back to Freedom for early analysis prior to transport back to Earth for detailed investigation.

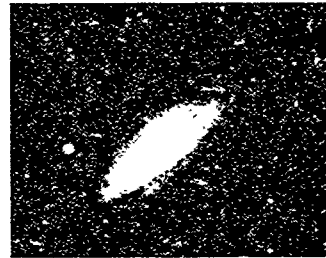

Future goals for the civil space program include an enhanced program of solar system exploration. Shown is the great nebula in Andromeda.

AP/WIDEWORLD



Freedom's large photovoltaic arrays could support development of high-performance, low-mass, high-reliability solar power for the early phases of lunar or Martian outposts.



Moon walker Charles Duke salutes the American flag during his 1972 Apollo mission. America's preeminence in the exploration of space was clearly demonstrated by Apollo's achievements.

Next Page: The Freedom Station will pave the way to making the solar system humanity's extended home.

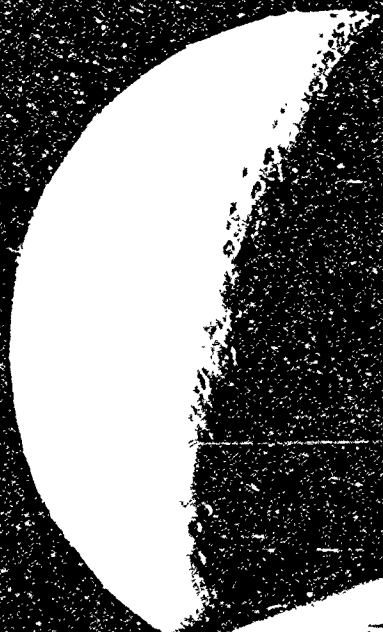
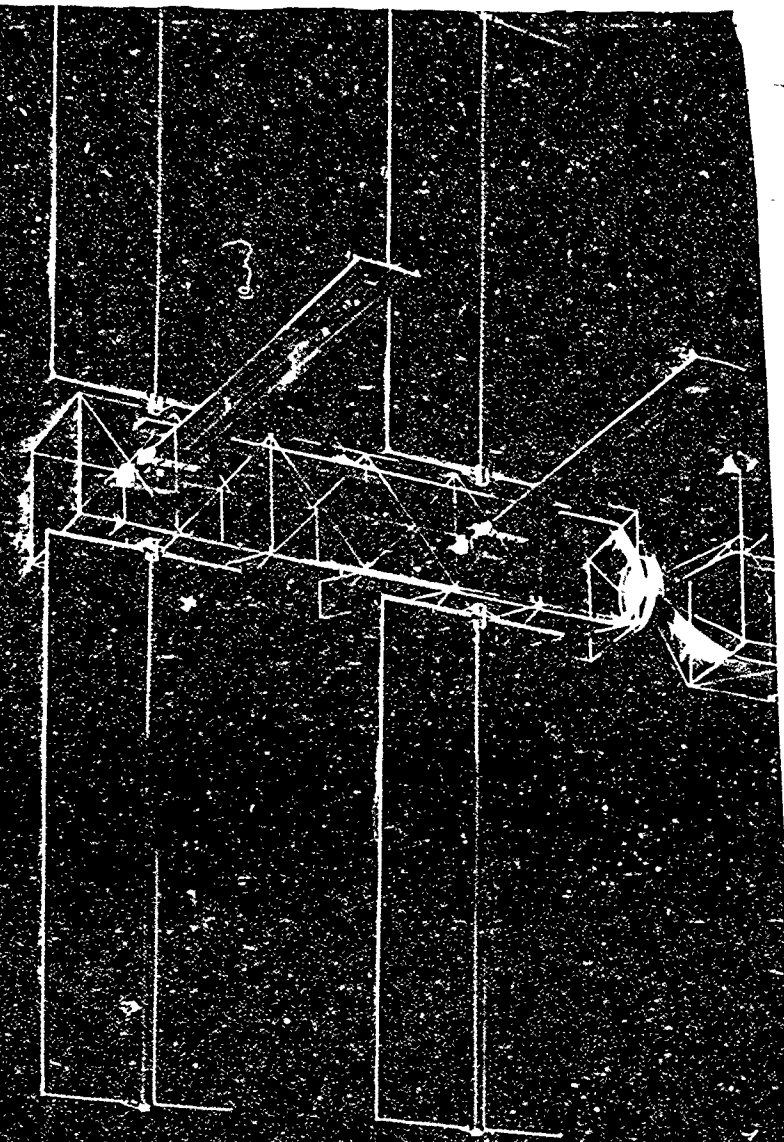

47

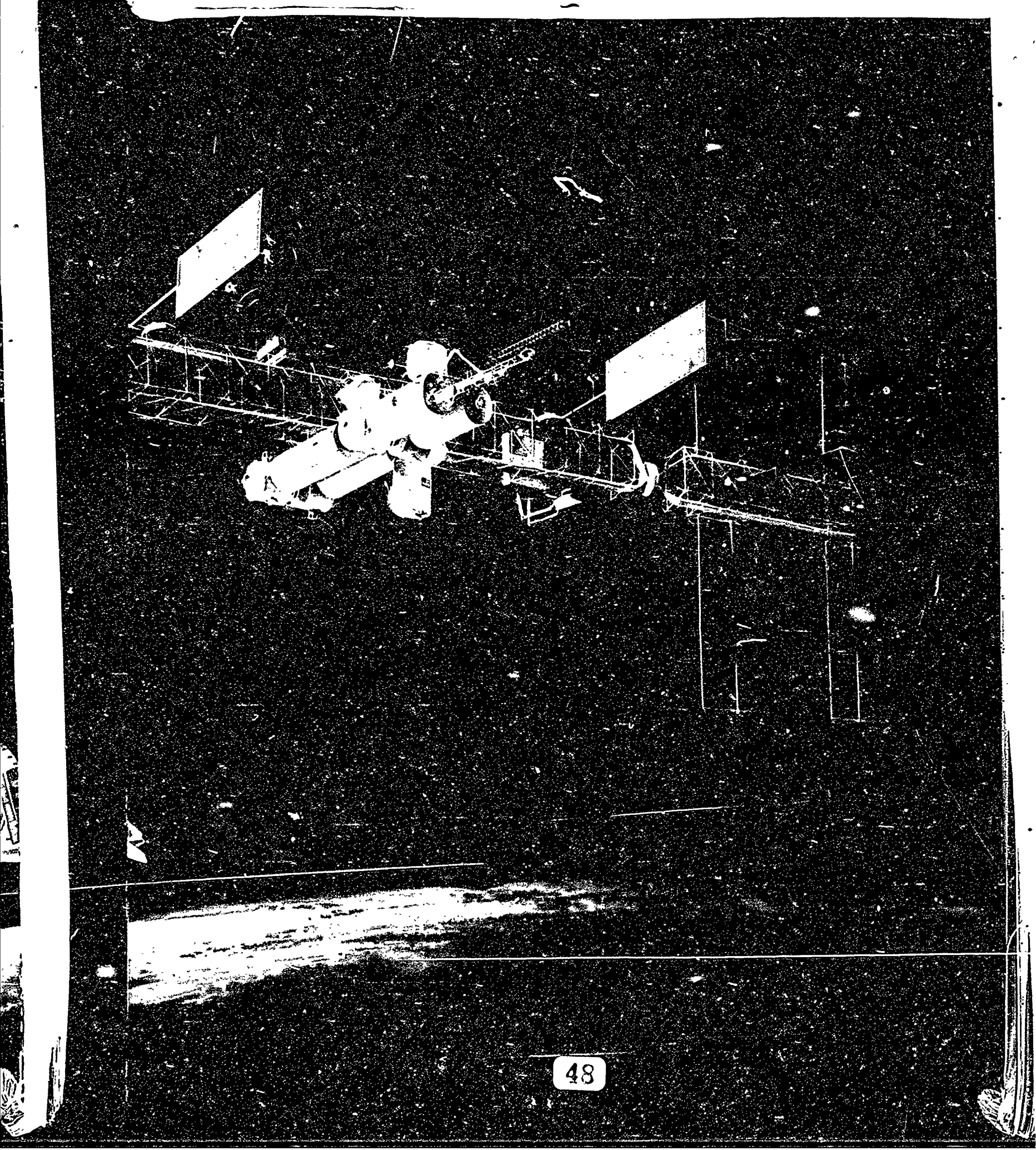

del
Aclor
Spe

NP-107/10-88

49